

Bell
412 EP

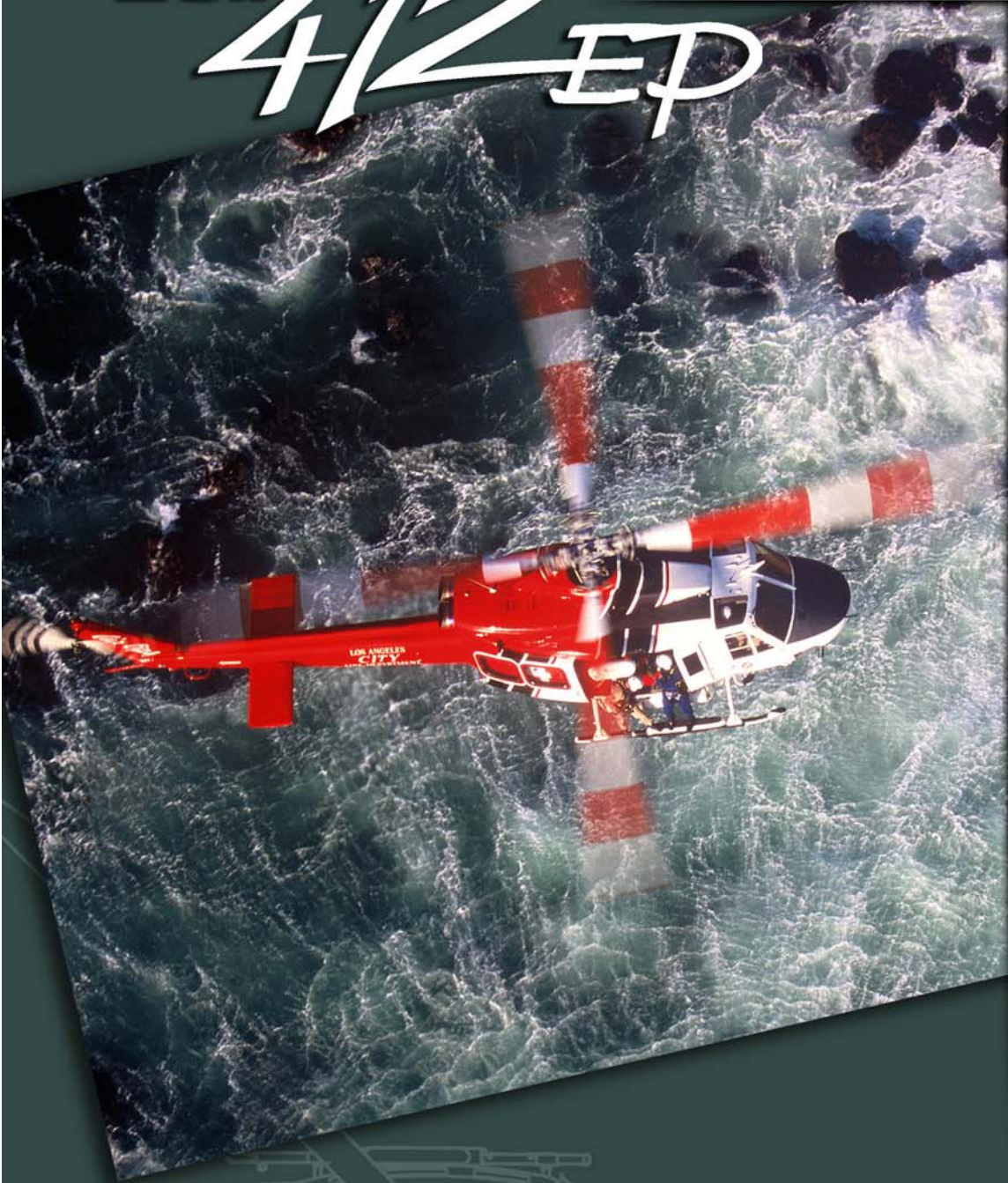

SPECIFICATIONS

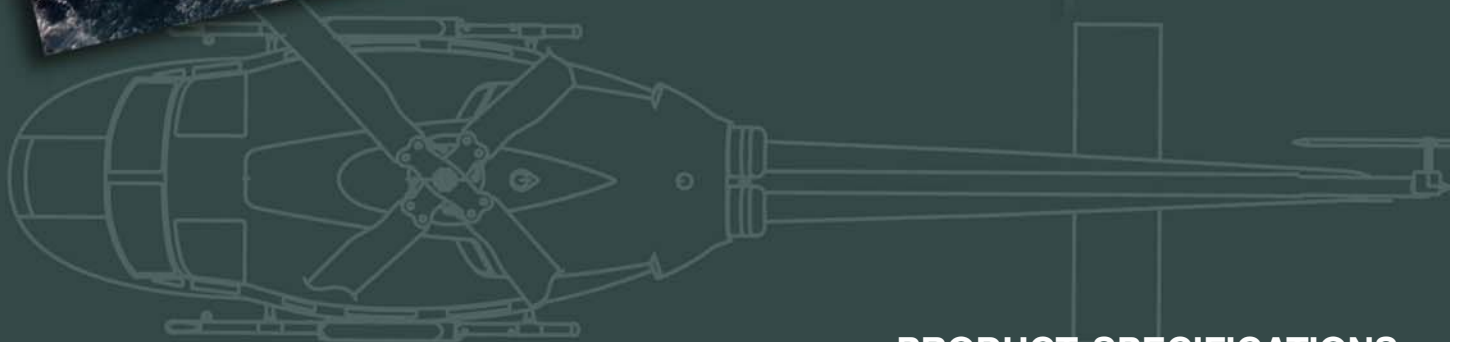

PRODUCT SPECIFICATIONS
JANUARY 2006

For additional information visit the Bell Helicopter Textron Website

Homepage: www.bellhelicopter.com

BELL HELICOPTER TEXTRON INC.

Sales Contact Telephone Numbers

Sales Inquiries

U.S. Toll Free: 1-800-FLY-BELL

International/US: 817-280-2800

Email: marketing@bellhelicopter.textron.com

Regional Sales Areas

US/Canada 817-280-6789

Asia Pacific 817-280-2197

Europe/Middle East/Africa 817-280-3261

Latin America 817-280-2879

Used Helicopter Sales / www.BellNetX.com 817-280-2147

Fax: 817-280-8802

Customer Center

Ft. Worth / Alliance Airport Facility

P. O. Box 482

Ft. Worth, TX 76101-0482

817-280-6187 Fax: 817-280-8802

marketing@bellhelicopter.textron.com

Manufacturing Facility

Bell Helicopter Textron Canada Limited

12,800 rue de l'Avenir

Mirabel, Quebec

Canada J7J 1R4

450-437-3400 Fax: 450-437-2006

This book was produced by



Visual Communications Center

P. O. Box 482

Ft. Worth, TX 76101-0482

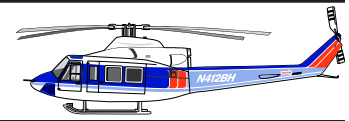

PUBLISHERS NOTICE

The data presented in this document is general in nature, and has been compiled from Bell Helicopter Textron, Inc. [BHTI] source materials including but not limited to; The Approved Rotorcraft Flight Manual, Maintenance Manual, Illustrated Parts Catalog, and other engineering design specifications.

This document is intended for the use of **BHTI Sales Personnel** and for **prospective customers** as an aid in determining estimated weight and performance of the helicopter when configured with equipment for specific missions.

Disclosure, reproduction, or use of any material in this document by persons other than BHTI employees, and BHTI independent representatives [International Dealers] is **forbidden** without written permission from Bell Helicopter Textron.

The listings of Optional Equipment [KITS] are subject to revision and change, and also may be different for specific serial number helicopters or special custom configurations. Please consult the *NOTES* found in the right margins of the optional equipment list pages for **equipment compatibility**. The continuing product improvement process of BHTI may cause some components, equipment, and compatibility to be changed or replaced.

The SPECIFICATIONS, WEIGHTS, DIMENSIONS, AND PERFORMANCE DATA shown in this document are subject to change without notice.



EXTERIOR DIMENSIONS

STANDARD LOW SKID GEAR

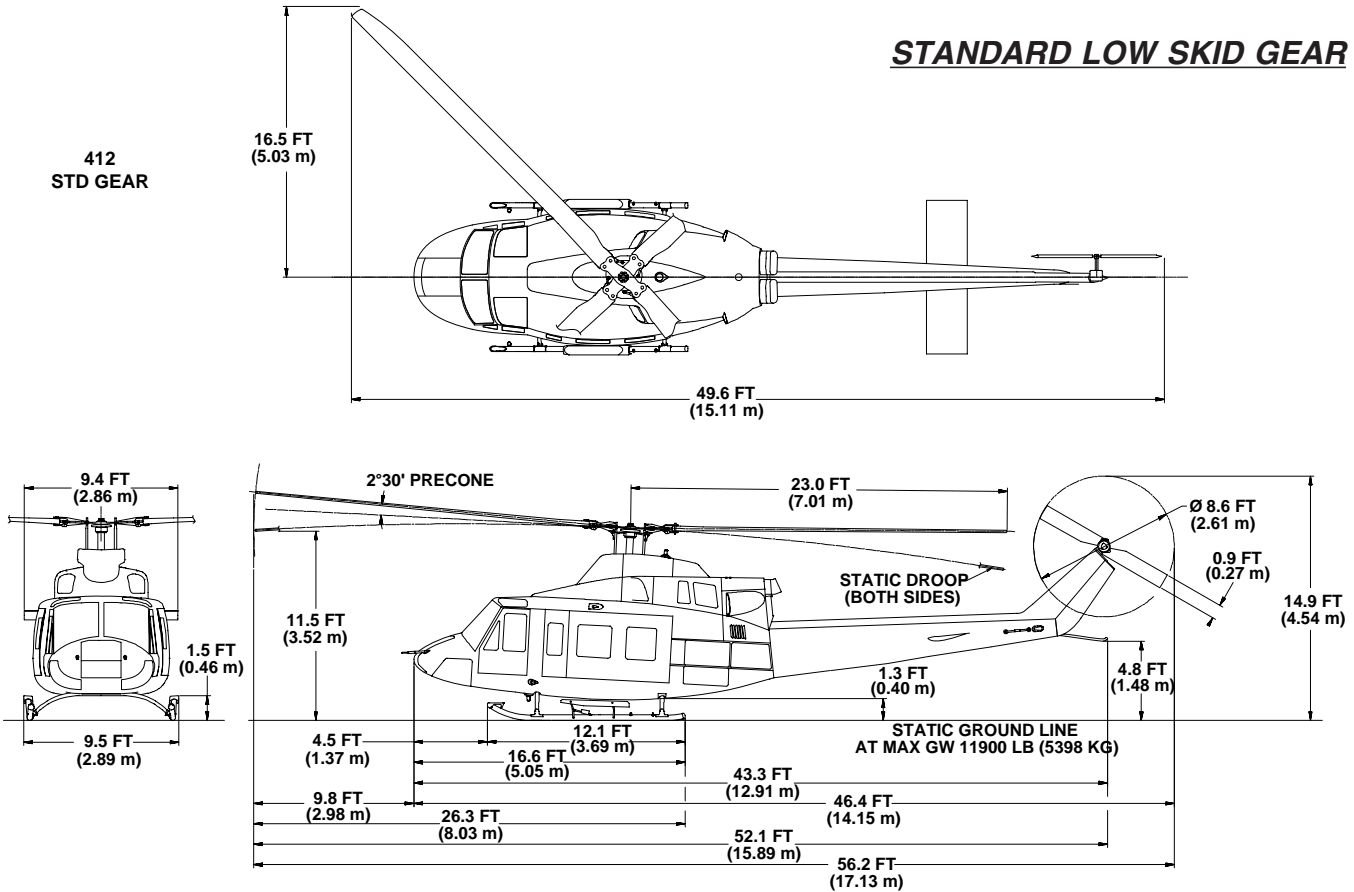

OPTIONAL HIGH SKID GEAR w/AAI FLIGHTSTEP®

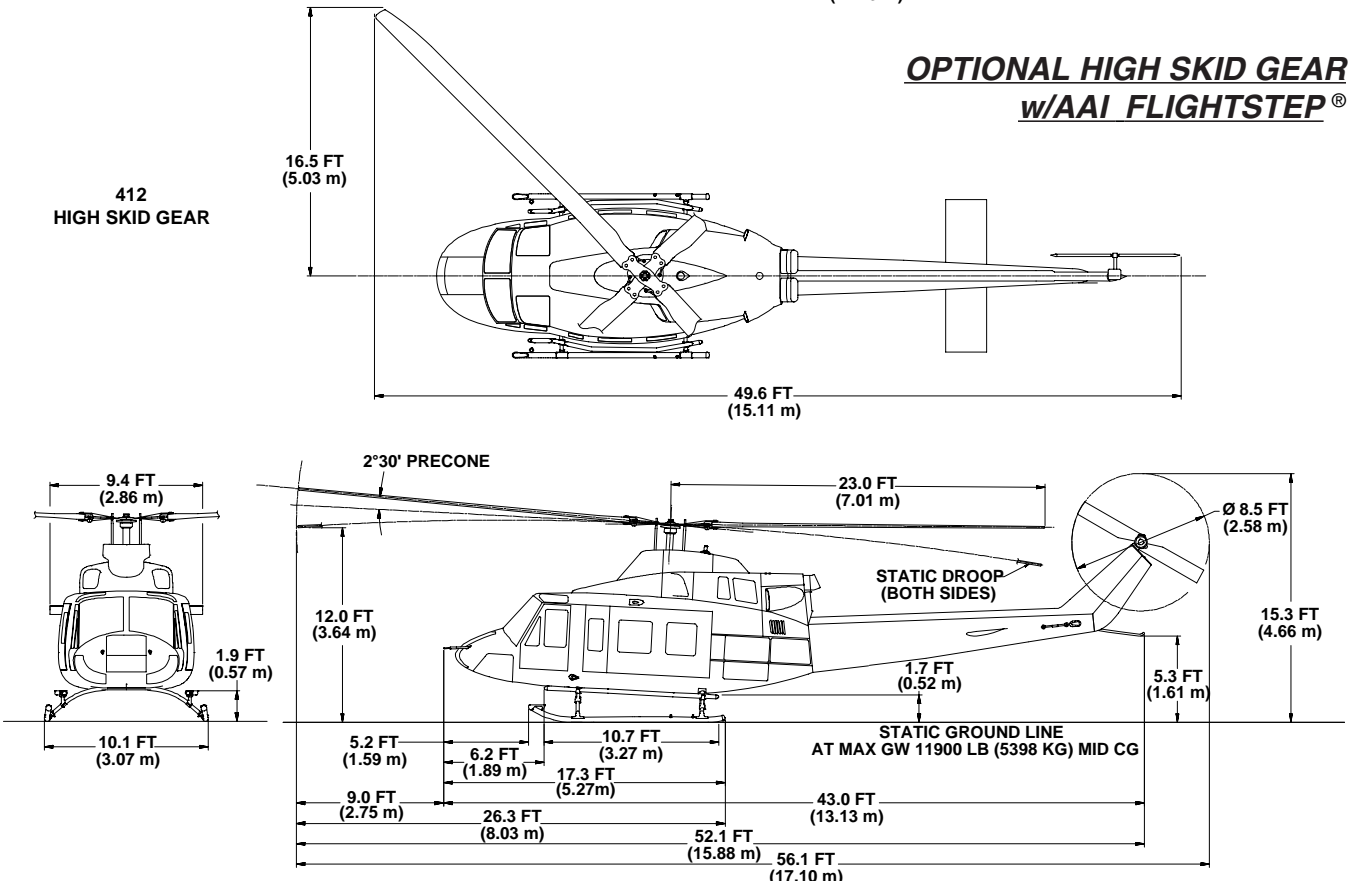



INTERIOR DIMENSIONS

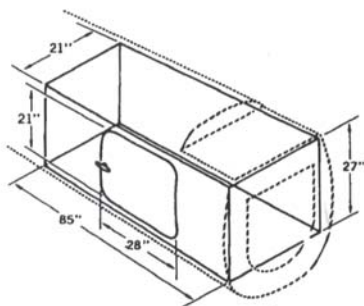
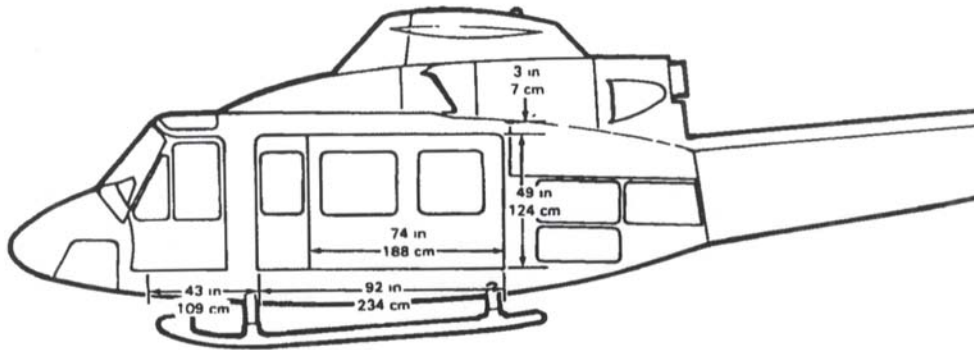
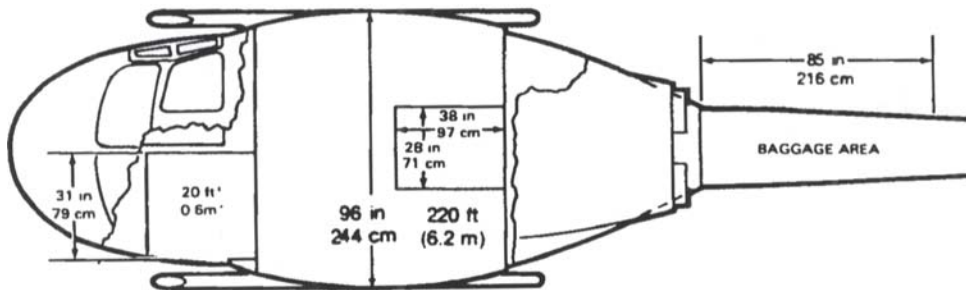

BAGGAGE COMPARTMENT

AREA & VOLUME

	AREA FT ² (M ²)	VOLUME FT ³ (M ³)
Left Crew Seat	7(0.7)	20(0.6)
Cabin	51(5.0)	220(6.2)
Baggage		
Compartment	12(1.0)	28(0.8)

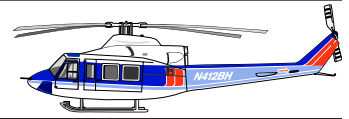

LEFT BLANK

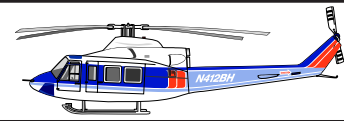

SPECIFICATION SUMMARY {U. S. Units}

(Serial No. 36366 & Subsequent)

<u>WEIGHTS</u>	<u>LBS</u>
VFR Standard Configuration Weight (Note 1,3)	6832
IFR Standard Configuration Weight (Note 2,3)	6935
Normal Gross Weight	11,900
External Load Gross Weight	11,900
VFR Standard Configuration Useful Load (Gross Wt-Standard Configuration Wt)	5068
IFR Standard Configuration Useful Load (Gross Wt-Standard Configuration Wt)	4965
Maximum External Load	4500

Note 1: Includes basic VFR configuration, AFCS, copilot seat, utility trim, 13 passenger seats and electrical provisions for optional avionic and IFR modifications.

Note 2: Includes IFR (FAA) modifications, copilot instruments, No. 2 VHF, No. 1 and 2 VOR/LOC/GS, ADF, standby attitude indicator, transponder, DME, Marker Beacon, dual controls and copilot clock. Passenger seats and trim as above.

Note 3: Includes twenty-five pounds of engine oil. **Ballast** is not included in standard configuration weight (ballast is a function of installed equipment).

PERFORMANCE SUMMARY: (International Standard Day Except as Noted)

• • • REFER TO DEMONSTRATED TAKEOFF & LANDING AND MAXIMUM OPERATING ALTITUDE NOTES ON THE PERFORMANCE CHARTS • • •

<u>TAKEOFF, GROSS WEIGHT</u>	<u>LBS</u>	<u>9500</u>	<u>10,500</u>	<u>11,900</u>
Hovering Ceiling (TOP capability)				
IGE Standard Day	ft	17,400	14,300	10,200
Standard Day+20 C	ft	14,400	10,900	6200
OGE Standard Day	ft	13,800	10,400	5200
Standard Day+20 C	ft	10,300	6400	(11,890lbs@SL)
FAA T/O and Ldg Limit, WAT (Note 4)				
Standard Day	ft	10,800	7600	3500
Standard Day+20 C	ft	8530	5340	1220
Service Ceiling (OEI, continuous power)	ft	11,450	8850	5400
Service Ceiling (OEI, OPTIONAL 30-Min Pwr) (Note 5)	ft	12,850	10,500	7600
Max Continuous Cruise TAS (sea level)	kts	126	125	122
Max Continuous Cruise TAS (5000 ft)	kts	133	131	124
Long Range Cruise Speed, 5000 ft (avg)	kts	131	131	130
Range (5000 ft)	n mi	423	414	402
Category A Takeoff and Landing Ceiling				
Elevated Helipad with ISA	ft	6000	3400	(11,580lbs@SL)
Optional PT6T-3DF engine ISA+20C	ft	3750	1200	(10,800lbs@SL)
Endurance, @ Loiter 70 kts SL, ISA (no reserve)	hr			3.7

Note 4: Does not apply for Category B, 9 passenger seat configuration. See FMS-35.3.

Note 5: Increased capability available with P&W PT6T-3DF (30 min. OEI Power Kit). See FMS-56.3/56.4

POWER RATINGS:

(Pratt & Whitney PT6T-3D Twin Pac) Uninstalled Thermodynamic Capability, Total	1800
Takeoff, SHP	1800
Max Continuous Power, SHP	1800
OEI SHP [2-1/2minutes]	1140
OEI SHP-standard continuous(optional PT6T-3DF engine w/30 min. OEI pwr.)	970 (1066)

TRANSMISSION RATINGS:

Takeoff, SHP (5-minute)(@ Mast)	1370
Max Continuous Power, SHP(@ Mast)	1110
Single Engine, SHP	1140

Fuel:

Type	Aviation Turbine
Capacity (Usable)	330.5 Gallons

THE DATA SET FORTH ON THIS DOCUMENT ARE GENERAL IN NATURE AND MAY VARY WITH CONDITIONS. FOR PERFORMANCE DATA AND OPERATING LIMITATIONS FOR ANY SPECIFIC FLIGHT MISSION, REFERENCE MUST BE MADE TO THE APPROVED FLIGHT MANUAL.



SPECIFICATION SUMMARY {Metric Units}

<u>WEIGHTS</u>	<i>(Serial No. 36366 & Subsequent)</i>	<u>KG</u>
VFR Standard Configuration Weight (Note 1,3)		3099
IFR Standard Configuration Weight (Note 2,3)		3146
Normal Gross Weight		5398
External Load Gross Weight		5398
VFR Standard Configuration Useful Load (Gross Wt-Standard Configuration Wt)		2299
IFR Standard Configuration Useful Load (Gross Wt-Standard Configuration Wt)		2252
Maximum External Load		2041

Note 1: Includes basic VFR configuration, AFCS, copilot seat, utility trim, 13 passenger seats and electrical provisions for optional avionic and IFR modifications.

Note 2: Includes IFR (FAA) modifications, copilot instruments, No. 2 VHF, No. 1 and 2 VOR/LOC/GS, ADF, standby attitude indicator, transponder, DME, Marker Beacon, dual controls and copilot clock. Passenger seats and trim as above.

Note 3: Includes eleven kilograms of engine oil. **Ballast** is not included in standard configuration weight (ballast is a function of installed equipment).

PERFORMANCE SUMMARY: (International Standard Day Except as Noted)

• • • REFER TO DEMONSTRATED TAKEOFF & LANDING AND MAXIMUM OPERATING ALTITUDE NOTES ON THE PERFORMANCE CHARTS • • •

<u>TAKEOFF, GROSS WEIGHT</u>	<u>KG</u>	<u>4309</u>	<u>4763</u>	<u>5398</u>
Hovering Ceiling (TOP capability)				
IGE Standard Day	m	5304	4359	3109
Standard Day+20 C	m	4389	3322	1890
OGE Standard Day	m	4206	3170	1585
Standard Day+20 C	m	3139	1844	(5393Kg@SL)
FAA T/O and Ldg Limit, WAT (Note 4)				
Standard Day	m	3192	2316	1067
Standard Day+20 C	m	2600	1628	372
Service Ceiling (OEI, continuous power)	m	3490	2697	1646
Service Ceiling (OEI, OPTIONAL 30-Min Pwr) (Note 5)	m	3917	3200	2316
Max Continuous Cruise TAS (sea level)	km/h	233	232	226
Max Continuous Cruise TAS (1524 m)	km/h	246	243	230
Long Range Cruise Speed, 1524 m (avg)	km/h	243	243	241
Range (1524 m)	km	784	767	745
Category A Takeoff and Landing Ceiling				
Elevated Helipad with ISA	m	1829	1036	(5252Kg@SL)
Optional PT6T-3DF engine ISA+20C	m	1143	366	(4899Kg@SL)
Endurance, @ Loiter 130 km/h SL, ISA (no reserve)	hr			3.7

Note 4: Does not apply for Category B, 9 passenger seat configuration. See FMS-35.3.

Note 5: Increased capability available with P&W PT6T-3DF (30 min.OEI Power Kit). See FMS-56.3/56.4

POWER RATINGS:

(Pratt & Whitney PT6T-3D Twin Pac)Uninstalled Thermodynamic Capability, Total Takeoff , kW	1342
Max Continuous Power, kW	1342
OEI SHP [2-1/2minutes]	850
OEI SHP [Continuous]-standard(optional PT6T-3DF engine w/30 min. OEI pwr.)	723(795)

TRANSMISSION RATINGS:

Takeoff , kW (5-minute)(@ Mast)	1022
Max Continuous Power, kW(@ Mast)	828
Single Engine, kW	850

Fuel:

Type	Aviation Turbine
Capacity (Usable)	1251 liters

THE DATA SET FORTH ON THIS DOCUMENT ARE GENERAL IN NATURE AND MAY VARY WITH CONDITIONS. FOR PERFORMANCE DATA AND OPERATING LIMITATIONS FOR ANY SPECIFIC FLIGHT MISSION, REFERENCE MUST BE MADE TO THE APPROVED FLIGHT MANUAL.



412 SEATING & INTERIOR TRIM CHOICES

CREW SEATS - Two individual **energy attenuating** seats, fore/aft and up/down adjustable, each equipped with **seat belt, double strap shoulder harness** and **inertia reel**. Available with Grey, Blue, Red, or Tan upholstery which will match that selected for the cabin.

PASSENGER SEATS - **13 seats offered in three options.** (NOTE: Seating option 1 meets the criteria required by FAA regulations for installation in U.S. registered helicopters. Seating Options 2 & 3 require the addition of the STC Alpine 412 Passenger Shoulder Harness Kit for installation in U.S. registered helicopters.)

STANDARD SEATING

[SHOWN WITH STANDARD INTERIOR TRIM AND FLOOR COVERING]

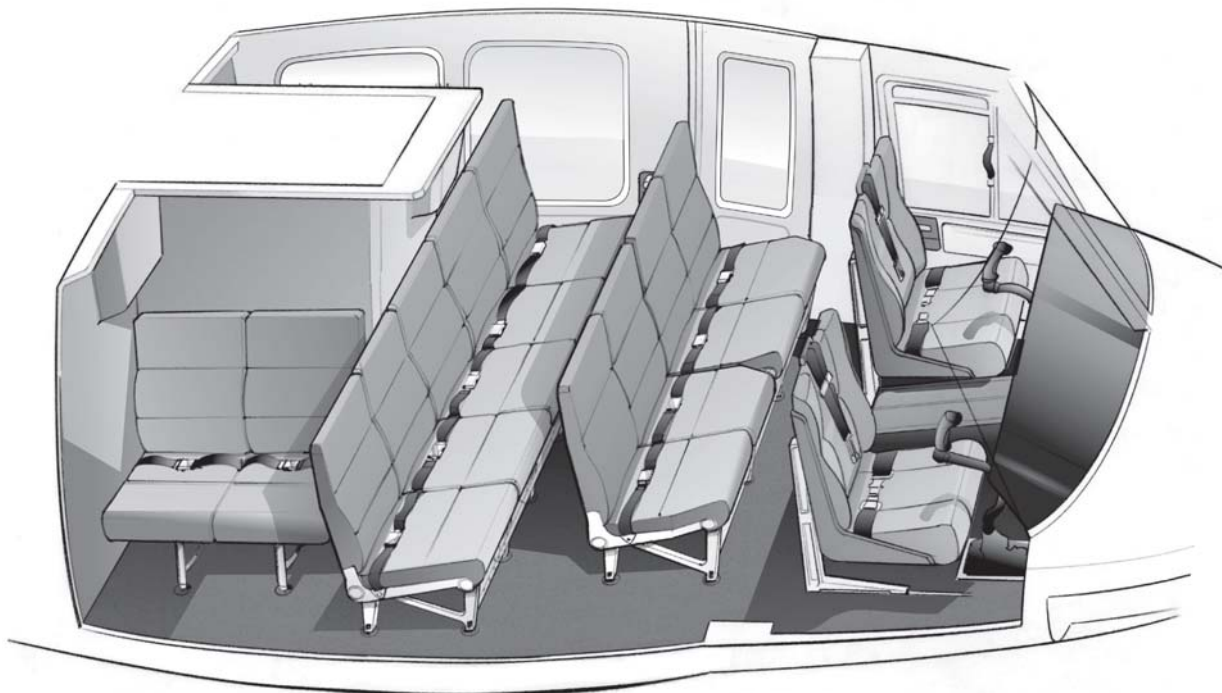

1) STANDARD SEATING - Fabric covered high-backed **folding** seats with individual seat belts and **single strap** shoulder harness and inertia reel, arranged with **one row of four** (2xtwo place benches) **forward facing seats**, and **one row of five** **forward facing seats**, and **two outward facing two place benches** (one on either side of the transmission). Available with Grey, Blue, Red, or Tan upholstery with Black seat belts. Seats are also available in all vinyl at additional cost. **(210.9 lbs. [95.7 Kg.] included** in the standard configuration weight.)

• • •

SEATING OPTIONS 2 AND 3 NOT ILLUSTRATED

• • •

2) UTILITY SEATING - Available for **U. S. registered helicopters ONLY** with addition of **STC Alpine 412 Passenger Shoulder Harness Kit**. Nylon covered bench type seating arranged with **one row of four rearward facing seats** (behind the crew seats), **one row of five forward facing seats** (in front of the transmission), and **two outward facing two place benches** (one on either side of the transmission). Each seat has an individual seat belt. Available in Tan or Black. The Utility Seating decreases the standard configuration weight **(-92.8 lbs. [-42.1 Kg.]**).

3) CUSHIONED UTILITY SEATING - Available for **U. S. registered helicopters ONLY** with addition of **STC Alpine 412 Passenger Shoulder Harness Kit**. As in 2) above with the addition of fabric covered cushions, available in the same colors as the Standard Seating. The Cushioned Utility Seating decreases the standard configuration weight **(-50.1 lbs. [-22.7 Kg.]**).



INTERIOR TRIM CHOICES

1) **STANDARD INTERIOR TRIM**- The Standard Interior Trim is provided as a **NO COST OPTION**, but is **not included** in the Standard Configuration Empty Weight. Included are: Plastic closeouts on upper sidewalls, window reveals, and cabin headliner; Padded vinyl covering the floor and lower door panels; Lower aft bulkhead covered with padded vinyl blankets. The hard plastic headliner and closeouts are off-white in color, and the padded bulkhead blankets and floor covering are color coordinated to match the seat color selection. The Standard Interior Trim **increases** the standard configuration empty weight **165.6 lbs. [75.1 Kg.]**

2) **UTILITY INTERIOR TRIM**- The Utility Interior Trim consists of: Light beige vinyl covered headliner and bulkhead blankets; Doors painted light beige; Floor painted brown. The Utility Interior Trim is **included** in the standard configuration empty weight (**32.6 lbs. [14.8 Kg.]**).

CUSTOMIZED SEATING

[EXAMPLE]

CUSTOMIZED SEATING - Custom designed interiors are available from aircraft completion centers to meet the needs of Corporate or Emergency Medical Service customers.

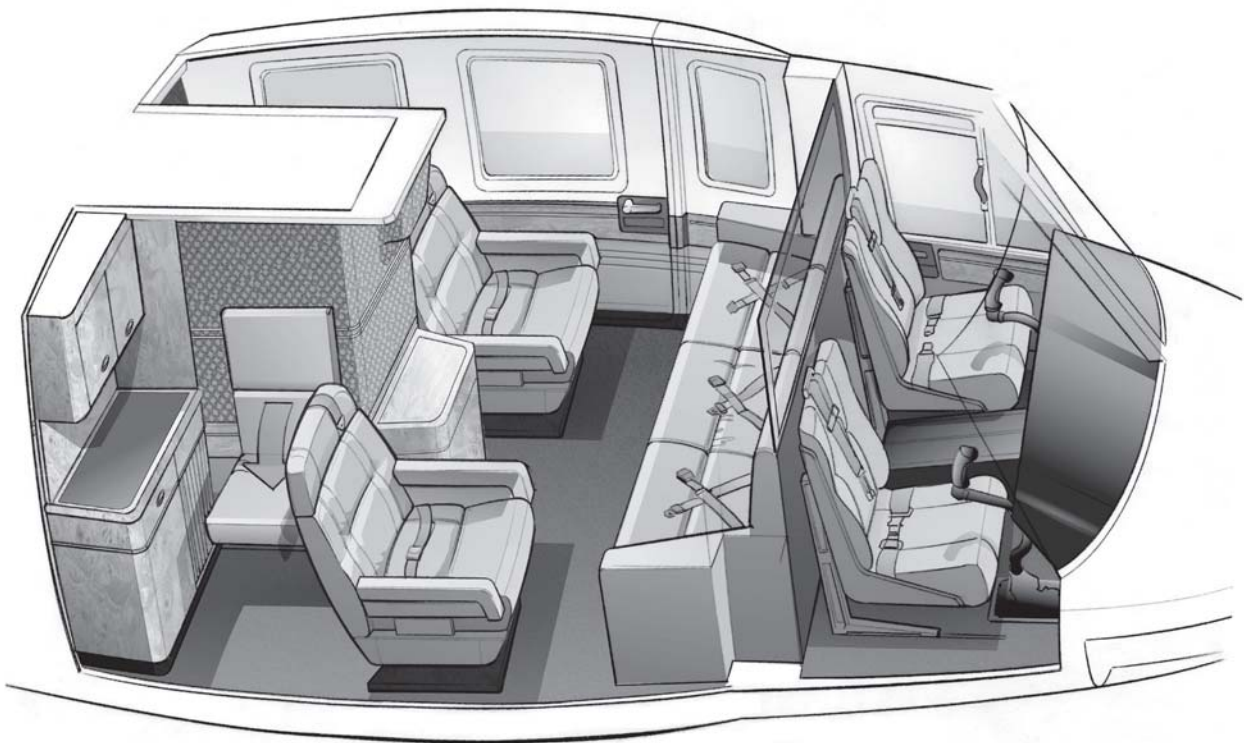



STANDARD CONFIGURATION **(Items Included In List Price)**

AIRFRAME

Aluminum alloy fuselage (over 240 ft³ [6.8M³]
loading space
Glass windshields
Tinted overhead windows
Dual windshield wipers
Fresh air ventilators with adjustable outlets (8
cockpit and 12 aft cabin)
Bleed air heater and defroster with air noise
suppression
Cargo tie-down fittings (51 aft cabin floor)
Ash trays, cockpit (2)
Map and data case
Cabin fire extinguisher (2)
Swingout jettisonable doors (2 for forward cabin)
Sliding doors (2 for aft cabin access with
2 emergency exit panels on each door)
Swingout panels for extended access to aft cabin
(2)
Fixed step on skids for entry to forward cabin (2)
Retractable steps for aft cabin access (2)
Baggage compartment in tail boom (over 28 ft³
[0.8M³], 400 lb. [181Kg] capacity).
Skid-type landing gear with replaceable wear
shoes
Mooring and jacking fittings (4)
External attachment fittings (16)
Semi-monocoque tailboom and vertical fin
Elevator [airspeed / spring-cartridge controlled]
Tail skid

ROTORS & CONTROLS

Soft-in-plane flex beam hub with four fiberglass
blades
Main rotor droop restraint
Pendulum vibration absorbers
Semi-rigid, two bladed all-metal tail rotor
All controls hydraulically boosted (dual systems for
main rotor)
Force trim system and artificial feel (electrically set)
Cyclic stick centering
RPM governor selector control
Manual engine torque matching and trim
Dual Digital Three axis AFCS (2 flight control
computers)

TRANSMISSION/ DRIVE SYSTEM

Main rotor transmission with 4 chip detectors/
2 debris collectors
Vibration isolation / suspension mounts (4)
Main Lift link (single point suspension)
42° gearbox (sight gage and magnetic drain
plug/chip detector)
90° gearbox (sight gage and magnetic drain
plug/chip detector)
Hydraulic pumps for controls (2 independent
systems)
Transmission oil cooler

POWER PLANT

Pratt & Whitney of Canada PT6T-3D "Twin Pac"
(1800 SHP)
Automatic governors (2)
Magnetic chip detectors
Torque limiter
Fuel System (330.5 US Gal [1251 liter] usable,
rupture resistant cells and breakaway vent
fitting)
Pumps on engines and submerged in fuel tanks
Fuel filter assembly
Oil coolers (2)
Fire detection system (2)
Fire extinguisher system (2)
RPM warning system
Hinged cowling
Starter-generators (2)
Power turbine RPM control actuators
Combining gearbox with chip detector
Separate firewall protection for each engine
Overriding clutches (2)
Extended Engine Exhaust Deflectors

COMMUNICATIONS & NAVIGATION

720 Channel VHF rec/trans transceiver [KTR-908]
VHF antenna
2 Headsets (pilot & copilot)
2 Intercommunication Panels (ICS) [pilot & copilot]
Emergency Transmit Switch
Horizontal Situation Indicator
Attitude Director Indicator
Attitude and Heading Reference Systems (2)
Cockpit voice recorder provisions

FLIGHT & ENGINE INSTRUMENTS

Free air temperature indicator
AL-300 Data Display
Pitot static system with electric pitot heat
Altimeter (barometric)
Clock, digital quartz chronometer
Hourmeter
Magnetic compass, pilot's standby
Airspeed indicator
Rate of climb indicator
Turn and slip indicator
Triple tachometer (rotor and engines)
Dual hydraulic press/temp indicator (2)
Gas producer tach indicator (2)
Triple torque indicator (Eng 1, Eng 2, mast)
Engine oil-temp/press indicator (2)
Turbine inlet temperature indicator (2)
Fuel pressure indicator
Transmission oil-temp/press indicator
Dual DC and AC voltmeters
Dual DC loadmeter
Fire detection warning (3)
Combining gearbox oil-temp/press indicator
Flight data recorder provisions



STANDARD CONFIGURATION (continued)

(Items Included In List Price)

Caution & Warning System - Master caution light on panel draws attention to the pedestal mounted annunciator panel when worded segments illuminate:

Engine oil press (2)	DC generator (2)
Trans oil press	Gen overheat (2)
Trans oil temp	AC inverter (2)
Comb box oil press	External power
Comb box oil temp	Battery switch
Chip detectors (5)	Battery temp
Fuel boost (2)	Hydraulic
Fuel filter (2)	Door locks
Fuel valve (2)	Heater
Fuel low (2)	Part sep off (2)
Fuel X feed	Rotor brake (2)
Emerg gov manual (2)	Caution panel

Master warning lights on the instrument panel draw attention to:

RPM	Eng 2 Out	Eng 2 Fire
Eng 1 Out	Eng 1 Fire	Baggage Fire
Cyclic centering		Over torque (mast)

ELECTRICAL

Generator (2) (30 volt, 200 ampere DC starter-generator derated to 150 amperes)
 Inverters (2), (450 volt ampere single phase, solid state)
 Nickel cadmium battery (40 ampere hours)
 Battery over-temp warning
 Generator voltage regulators
 Instrument (integral) lights (white)
 Navigation lights
 Landing light-retractable
 Anticollision light (2)
 Searchlight-controllable

Tritium lighted emergency exit signs
 Cockpit lights (2)
 Dome lights (3)
 External power receptacle
 Twin ignition and starting systems
 Seat belt sign
 Passenger step lights
 Baggage compartment light & fire sensor
 Utility cabin lights (removable)

MISCELLANEOUS

Covers, tail pipe, turbine air inlet, and pitot tube
 Flight bag
 Ground handling wheels, hydraulically activated
 Manuals: Aircraft log, Engine log, Engine operations, Flight, Maintenance & Overhaul Manual, Illustrated Parts Catalog
 Tie-down assemblies, main rotor & tail rotor

INTERIOR TRIM

Choice of Standard or Utility Interior Trim.

Standard; Rigid three-piece headliner in cabin, padded fiberglass floor covering, bulkheads, trimmed with cream-colored plastic and color-coordinated vinyl coated fiberglass, cabin doors trimmed with plastic, special soundproofing, seat upholstered with foam and fabric. Selection of fabric colors. **Not included** in Standard Configuration Weight, increases empty weight 165.6 pounds (75.1 kilograms) when installed.

Utility; Beige soundproofing blankets on bulkheads and overhead; doors painted beige, floor painted brown. **Included** in Standard Configuration Weight [approximately 32.6 pounds 914.8 kilograms].



OPTIONAL ACCESSORIES

[KITS LISTED BELOW ARE COMPATIBLE WITH THE FAA IFR 3-AXIS / NON-EFIS CONFIGURATION EXCEPT AS INDIVIDUALLY NOTED]

ADDITIONAL KITS & STC ITEMS MAY BE AVAILABLE FOR FACTORY INSTALLATION. PLEASE CONSULT SALES OR CONTRACT PERSONNEL REGARDING SPECIAL NEEDS PRIOR TO SELECTION OF FINAL CONFIGURATION.

Kit Description	Wt (lbs)	Wt (Kg)	Notes
AIRFRAME			
FIXED STEP LEFT HAND	1.0	0.5	(1, 2)
FIXED STEP RIGHT HAND	1.0	0.5	(1, 2)
HEAVY DUTY HIGH SKID GEAR w/o STEPS	33.9	15.4	(1, 3)
HEAVY DUTY HIGH CROSS TUBES FOR EMER. FLOATS	17.2	7.8	
EMERGENCY FLOATS (PROVISIONS)	52.0	23.6	(4)
EMERGENCY FLOATS / RESERVOIR & NOSE	98.4	44.6	(4)
EMERGENCY FLOATS (L. G. w/ FLOATS & PWR. STEPS)	169.0	76.7	(1, 4)
AUX. FUEL LEFT HAND (82 GAL)			(5)
AUX. FUEL RIGHT HAND (82 GAL)			(5)
WT. CHG. UTILITY [SOFT] INTERIOR PER SIDE	46.7	21.2	(1)
WT. CHG. STANDARD [HARD] INTERIOR PER SIDE	39.6	18.0	(1)
AUX. FUEL PROVISIONS (164 GAL)	5.1	2.3	(5)
AUX. FUEL 32.8 GAL / 16.4 GAL EA. SIDE			(6)
WT. CHG. UTILITY [SOFT] INTERIOR [PAIR]	36.8	16.7	(1)
WT. CHG. STANDARD [HARD] INTERIOR [PAIR]	30.3	13.7	(1)
HEATED WINDSHIELD	9.8	4.4	(1)
EXPANDABLE BOLTS - MAIN ROTOR	3.0	1.4	
FUEL KIT - MANIFOLD DRAIN	0.3	0.1	
AUDIO			
TWO STATION AFT INTERCOM SYSTEM W/CREW INTERFACE	7.5	3.4	
AVIONICS			
EFIS - (ELECTRONIC FLIGHT INSTRUMENT SYSTEM)	115.6	52.4	(1,7)
4-AXIS DAFCS W/ DUAL FLIGHT DIRECTOR	26.0	11.8	(8)
PRIMUS 700 WEATHER RADAR	50.0	22.7	
PRIMUS 700 WEATHER RADAR W/ EFIS	55.5	25.2	(8)
ENCODING ALTIMETER (4-AXIS)	0.8	0.4	(1, 8)
ENCODING ALTIMETER / MILIBARS (4-AXIS)	0.8	0.4	(1,8)
ENCODING ALTIMETER IN./ MILIBARS (3-AXIS)	0.3	0.1	(1)
FLIGHT DIRECTOR NAV COUPLER (3-AXIS)	6.5	2.9	(9)
RADAR ALTIMETER #1	6.5	2.9	(8, 9)
RADAR ALTIMETER #2	12.1	5.5	(8)
ENGINE			
INCREASED CONTINUOUS POWER RATING W/O 30 MIN OEI	0.0	0.0	(1)
INCREASED CONTINUOUS POWER RATING	0.0	0.0	(1)
30 MINUTE OEI (PT6T-3DF ENGINE)	0.0	0.0	(1)
30 MINUTE OEI (PT6T-3DF ENGINE) CONTINUOUS POWER	0.0	0.0	(1)
ENVIRONMENT			
HEAVY DUTY HEATER	10.3	4.7	(1)

Specifications subject to change without notice.



OPTIONAL ACCESSORIES (continued)

[KITS LISTED BELOW ARE COMPATIBLE WITH THE FAA IFR 3-AXIS / NON-EFIS CONFIGURATION EXCEPT AS INDIVIDUALLY NOTED]

Kit Description	Wt (lbs)	Wt (Kg)	Notes
EQUIPMENT			
ROTOR BRAKE	31.9	14.5	
3-PLACE LITTER KIT (NON FAA AIRCRAFT)	-99.2	-45.0	(1, 10
CARGO HOOK PROVISIONS	7.0	3.2	(11
CARGO HOOK (COMPLETE)	40.9	18.6	(11
CARGO HOOK EQUIPMENT	33.8	15.3	(11
INTERNAL RESCUE HOIST	182.6	82.8	(12
INTERNAL RESCUE HOIST SLING (ONLY)	10.1	4.6	
GROSS WEIGHT TOWING PULLER EQUIPMENT (LOOSE)	N/A	N/A	
SAR PROVISIONS (INTERFACE KIT ONLY)	3.8	1.7	(8
LITTER KIT (FAA AIRCRAFT)	-96.0	-43.5	(1, 10
INTERNAL HOIST PROVISIONS	8.9	4.0	
HOIST CABLE GUARD	5.2	2.4	
INCREASED GENERATOR CAPACITY	0.7	0.3	(1
TRANSMISSION POWER TAKE OFF	27.9	12.7	
GROSS WEIGHT TOWING PULLER PROVISIONS	2.9	1.3	
CREW DOOR MIRROR	0.3	0.1	
53 AMPS HOUR BATTERY KIT W / EFIS	15.8	7.2	(1, 7, 8
53 AMPS HOUR BATTERY W/ FLOATS	15.8	7.2	(1, 7, 8
BATTERY CABLE KIT F/ WEATHER RDR PROV.	1.4	0.6	(1, 7, 8
FRAHM DAMPER	19.1	8.7	
INSTRUMENT			
COCKPIT VOICE RECORDER	11.4	5.2	(13
FLIGHT DATA RECORDER EQUIPMENT	23.9	10.8	(13
INTERIOR			
UTILITY SEATS (RAG AND TUBE-NOT FAA)	-92.8	-42.1	(1, 14
SEAT CUSHIONS (FOR RAG & TUBE SEATS)	42.7	19.4	(14
ONE MAN SEATS[2 FWD FACING REPLACE 4 LH/RH SIDE FACING]	-2.5	-1.1	(1
STANDARD INTERIOR [HARD PLASTIC]	165.6	75.1	(1
PAINT			
MARKINGS FOR HIGH VISIBILITY M/R BLADES (WHITE & ORANGE)	0.0	0.0	(15



OPTIONAL ACCESSORIES (continued)

[KITS LISTED BELOW ARE COMPATIBLE WITH FAA IFR 3-AXIS / NON-EFIS CONFIGURATION EXCEPT AS INDIVIDUALLY NOTED]

Kit Description	Wt (lbs)	Wt (Kg)	Notes
STC's			
EQUIPMENT			
ALPINE SHOULDER HARNESS KIT (FOR UTILITY SEATS)	33.8	15.3 (14	
WIRE STRIKE - RECOMMENDED KIT - SEE NOTE	20.0	9.1 (16	
Credits			
EQUIPMENT			
GROUND HANDLING WHEELS	180.0	81.6	
PAINT			
NO EXTERIOR PAINT	-30.9	-14.0	
WHITE PAINT ONLY	0.0	0.0	



EXPLANATORY NOTES:

All equipment kits require Provision Kits prior to installation

Notes: For commonality, notes shown below are identical in Product Specification and Price List.

- (1) Price and / or Weight includes credit for basic ship hardware removed.
- (2) FAA requires **either** standard electric powered steps **or** fixed steps to conduct passenger carrying operations. Weight change is for replacement of low skid gear powered steps. Fixed step actual weight 11.7lb (5.3kg) each. Fixed steps not compatible with emergency pop out floats or rescue hoist.
- (3) FAA requires either standard electric powered steps or fixed steps to conduct passenger carrying operations. For powered passenger steps add 21.5lb (9.8kg); For fixed steps add 23.4lb (10.6kg).
- (4) For a complete installation of Emergency Floats (412-706-004-153, -163, and -165) are required.
- (5) Aux Fuel Provision Kit (412-706-007-121) must be installed prior to or concurrently with installation of kits (412-706-007-119 & -120).
- (6) Aux Fuel Kit 32.8 Gal (412-706-009-117) includes integral provisions.
- (7) EFIS is compatible with 4-axis level 1&2; See Table on AFCS configuration page. **3-axis EFIS** can be **customized**. EFIS **requires** installation of 53 AMP Hour Battery. Different Kits are required for Std. Landing Gear(412-706-059-101), Floats(412-706-059-103), and an additional kit is required if Weather Radar(412-706-059-105) is installed.
- (8) **4-Axis** Level 2 & 3 AFCS configurations **require** FAA IFR configuration and installation of **additional equipment kits**. See the tables on the AFCS configuration pages for items required and installed weight.
- (9) **3-Axis** Level 1 AFCS configurations **requires** FAA IFR configuration and installation of **additional equipment kits**. See the tables on the AFCS configuration pages for items required and installed weight.
- (10) The 412-706-006-105 Litter Kit is FAA certified equipment. The 205-706-047-011 Litter Kit is not FAA certified. Weights are for all standard seats removed with three litters and attendant seat(s) installed.
- (11) Cargo Hook Prov. (212-706-103-103) must be installed prior to ,Cargo Hook Equip.(212-706-103-109).
- (12) **Requires** installation of provisions (412-706-011-105), Cable Guard (412-706-017-101), and Two Station Aft Cabin ICS (412-706-012-107).
or more seats.
- (14) Utility Seating is available on U. S. registered helicopters **ONLY** with the addition of the STC'd Alpine 412 Passenger Shoulder harness Kit.
- (15) Standard or High Visibility Main Rotor Blade Paint to be specified by Sales Order.
- (16) The Wire Strike Kit is a RECOMMENDED **extra cost** option. The customer must specify on the Purchase Agreement for the WSPS Kit **NOT** to be installed.

STC Kits - Select Supplemental Type Certificated Optional Equipment Kits are available for installation at the Bell Helicopter Textron factory. Please contact your Bell Sales Representative for availability and pricing information.

P.O.R. - Priced On Request.



BELL 412EP OPTIONAL DUAL DIGITAL AFCS CONFIGURATIONS*

IFR (FAA) Configuration

	(lb)	(Kg)
DUAL CONTROL	25.5	11.6
CO-PILOT CLOCK	0.2	0.1
DME (KDM-706)	6.5	2.9
FAA IFR	3.2	1.5
ADF (KDF-806)	7.2	3.3
NAV 1 VOR/LOC w/ GS (KNR-634)	10.1	4.6
NAV 2 VOR/LOC w/ GS (KNR-634)	7.8	3.5
VHF COMM#2 (KTR-908)	6.3	2.9
TRANSPONDER (MST-67A)	10.2	4.6
CO-PILOT INSTRUMENTS	17.8	8.1
STANDBY ATTITUDE INDICATOR	8.5	3.9
Installed Weight IFR (FAA) Configuration	103.3	46.9

LEVEL 1

3-AXIS DUAL

With Flight Directors, without EFIS

3-AXIS DDAFCS w/ DUAL FD	6.5	2.9
RADAR ALTIMETER NO.1	6.5	2.9
Installed Weight Level 1.	116.3	52.8

* OTHER CONFIGURATION CAN BE DEVELOPED TO MEET SPECIFIC CUSTOMER REQUIREMENTS.

Specifications subject to change without notice.



DUAL DIGITAL AFCS OPERATING PARAMETERS

LEVEL 1 : Standard Flight Director modes; ALT, IAS, VS, HDG, NAV, ILS, BC, VOR APR, GA.

LEVEL 2 : Same as Level 1 Plus; Simultaneous ALT and IAS, Simultaneous IAS and VS, Altitude Pre-Select (ALTPRE)[barometric level-off], Hover Hold (RAD ALT), ILS decelerate, and YAW Autotrim.

LEVEL 3 : Same as Level 2 Plus; AP1-Approach (decelerate to 60 Knots and 200 feet Radar Altitude), AP2-Auto-Approach (decelerate to hover), VEL HLD(Doppler Hover Hold), Mark on Target, Programed Search Patterns and Climb.

BELL 412EP OPTIONAL DUAL DIGITAL AFCS CONFIGURATIONS*

LEVEL 2
4-AXIS DUAL

With Flight Directors, with EFIS

	(lb)	(Kg)
See Level 1. 3-AXIS DUAL, With Flight Directors, w/o EFIS **	116.3	52.8
EFIS (4-TUBES)	115.6	52.4
BATTERY, 53 AMP-HR	15.8	7.2
4-AXIS DDAFCS	26.0	11.8
ENCODING ALTIMETER	0.8	0.4
Installed Weight	274.5	124.5

* OTHER CONFIGURATION CAN BE DEVELOPED TO MEET SPECIFIC CUSTOMER REQUIREMENTS.

** THE FAA IFR CONFIGURATION & LEVEL 1 (3-AXIS DUAL) IS REQUIRED IN ADDITION TO THE EQUIPMENT LISTED ABOVE.

Note:

- EFIS, ENCODING ALTIMETER AND RADAR ALT #1 ARE REQUIRED FOR ALL 4-AXIS CONFIGURATIONS.
- ENCODING ALTIMETER (4-AXIS) WITH (412-706-022-165) OR WITHOUT MILIBARS (412-706-022-167).

Specifications subject to change without notice.



BELL 412EP OPTIONAL DUAL DIGITAL AFCS CONFIGURATIONS*

LEVEL 3
4-AXIS DUAL

With Flight Directors, with EFIS
Auto approach Integrated SAR

	(lb)	(Kg)
See Level 1. 3-AXIS DUAL, With Flight Directors, w/o EFIS **	116.3	52.8
EFIS (4-TUBES)	115.6	52.4
BATTERY, 53 AMP-HR	15.8	7.2
4-AXIS DDAFCS	26.0	11.8
ENCODING ALTIMETER	0.8	0.4
RADAR ALTIMETER NO.2	12.1	5.5
SAR INTERFACE KIT	3.7	1.7
DOPPLER 91	37.1	16.8
UNS-1D	40.3	18.3
WX/SEARCH RADAR with DISPLAY (5th TUBE)	55.5	25.2
BATTERY CABLE KIT WX RADAR PROV.	1.4	0.6
DATA NAV V (OPTIONAL)	19.8	9.0
Installed Weight	444.4	201.6

* OTHER CONFIGURATION CAN BE DEVELOPED TO MEET SPECIFIC CUSTOMER REQUIREMENTS.

** THE FAA IFR CONFIGURATION & LEVEL 1 (3-AXIS DUAL) IS REQUIRED IN ADDITION TO THE EQUIPMENT LISTED ABOVE.

Note:

- EFIS, ENCODING ALTIMETER AND RADAR ALT #1 ARE REQUIRED FOR ALL 4-AXIS CONFIGURATIONS.
- ENCODING ALTIMETER (4-AXIS) WITH (412-706-022-165) OR WITHOUT MILIBARS (412-706-022-167).
- LEVEL 3 REQUIRES RADAR ALT #2 CONFIGURATION WEIGHT SHOWN DOES NOT INCLUDE EMERGENCY FLOATATION OR RESCUE HOIST.

Specifications subject to change without notice.



HOVER PERFORMANCE CHARTS
COMBINED WAT * LIMITED AND HOVER CAPABILITY
10 OR MORE PASSENGER SEATS
and 9 OR LESS PASSENGER SEATS
PT6T-3D ENGINE
ENGINE CONTINUOUS POWER
TRANSMISSION TAKEOFF POWER

The following Hover Performance Charts are presented in a revised format which should simplify the comparison of Weight Altitude Temperature (WAT) limited Take Off and Landing Capability and the Hover Capability for known favorable wind conditions.*

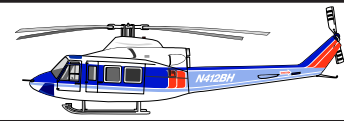

IGE HOVER PERFORMANCE
COMBINED WAT LIMITED AND HOVER CAPABILITY
10 OR MORE PASSENGER SEATS
and 9 OR LESS PASSENGER SEATS
PT6T-3D ENGINE
ENGINE CONTINUOUS POWER
TRANSMISSION TAKEOFF POWER

EXAMPLE

WANTED

IGE HOVER WEIGHT, FOR THE 9 OR LESS PASSENGER SEAT CONFIGURATION.

KNOWN

PRESSURE ALTITUDE = 9000 FT
OAT = 10°C

METHOD

STEP 1. TO DETERMINE THE IGE HOVER WEIGHT, ENTER THE IGE HOVER CAPABILITY CHART AT A PRESSURE ALTITUDE OF 9000 FT. MOVE HORIZONTALLY TO THE RIGHT TO INTERSECT THE 10°C LINE. MOVE VERTICALLY DOWN TO READ A HOVER CAPABILITY OF 11,490 LB.

STEP 2. TO DETERMINE THE WAT LIMITED GROSS WEIGHT, ENTER THE IGE WAT LIMITATION CHART AT 10°C. DROP VERTICALLY DOWN TO INTERSECT THE 9000 FT PRESSURE ALTITUDE LINE. MOVE HORIZONTALLY TO THE RIGHT TO INTERSECT THE 9 OR LESS PASSENGER SEATS WAT LINE. MOVE VERTICALLY UP TO READ 10,900 LB. THIS IS THE WAT LIMITED GROSS WEIGHT.

STEP 3. THE LOWER OF STEP 1 AND STEP 2 WILL RESULT IN A CORRECT IGE HOVER WEIGHT OF 10,900 LB.



IGE HOVER CAPABILITY

GROSS WEIGHT - 100 KG

32 34 36 38 40 42 44 46 48 50 52 54

Compare hover capability with WAT limitations. The lower of the two gross weights determined is the correct hover performance. See example on preceding page.

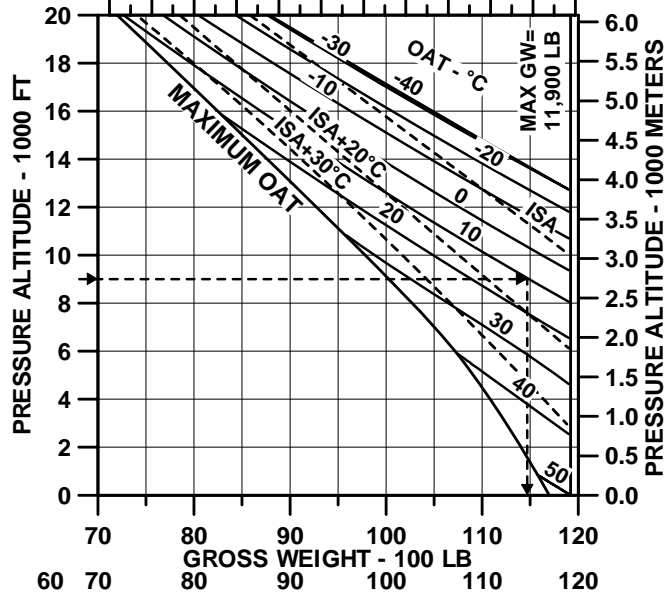

IGE HOVER WAT LIMITATION

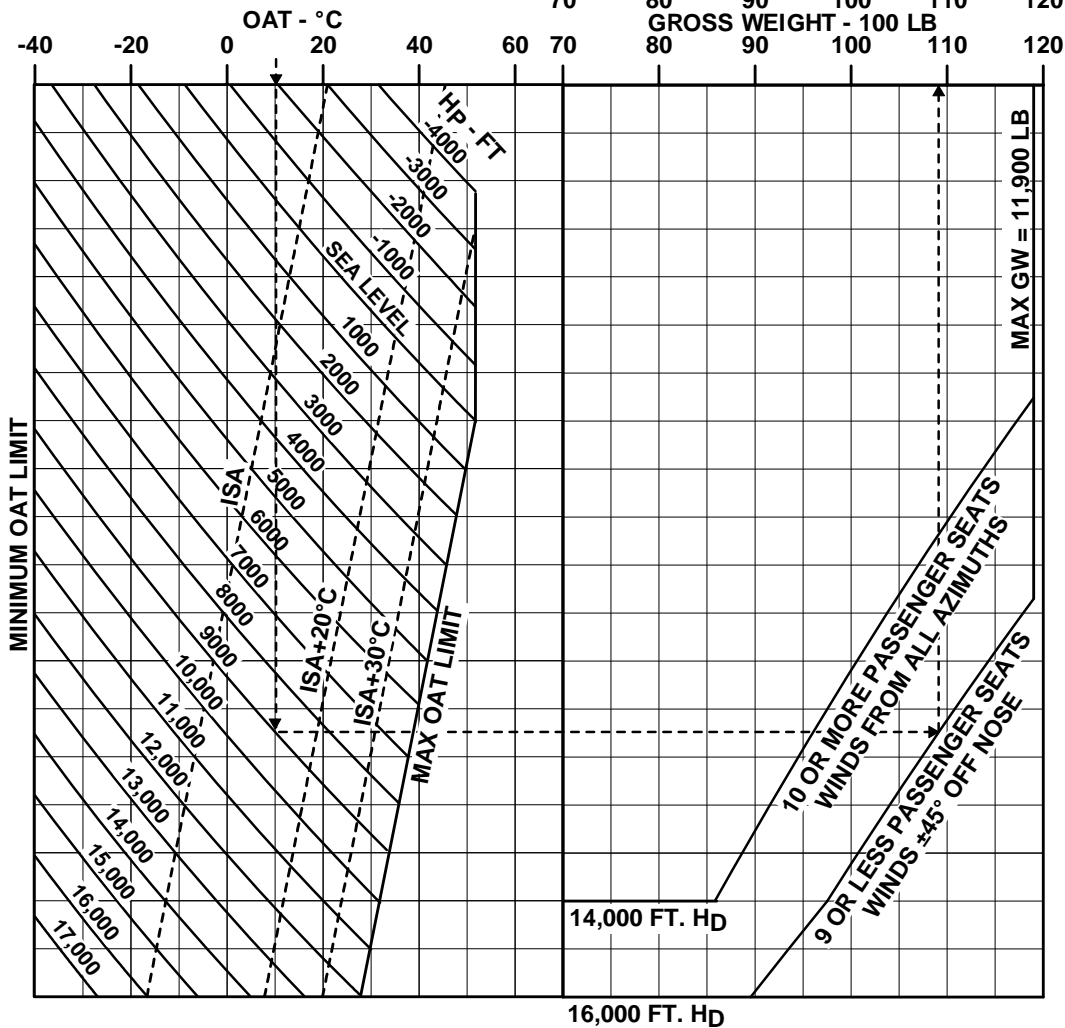

THE DATA SET FORTH ON THIS DOCUMENT ARE GENERAL IN NATURE AND MAY VARY WITH CONDITIONS. FOR PERFORMANCE DATA AND OPERATING LIMITATIONS FOR ANY SPECIFIC FLIGHT MISSION, REFERENCE MUST BE MADE TO THE APPROVED FLIGHT MANUAL.



OGE HOVER PERFORMANCE
COMBINED WAT LIMITED AND HOVER CAPABILITY
10 OR MORE PASSENGER SEATS
and 9 OR LESS PASSENGER SEATS
PT6T-3D ENGINE
ENGINE CONTINUOUS POWER
TRANSMISSION TAKEOFF POWER

FOR USE OF THE CHART,
SEE THE EXAMPLE ON THE PRECEDING PAGES



OGE HOVER CAPABILITY

GROSS WEIGHT - 100 KG
32 34 36 38 40 42 44 46 48 50 52 54

Compare hover capability with WAT limitations. The lower of the two gross weights determined is the correct hover performance.

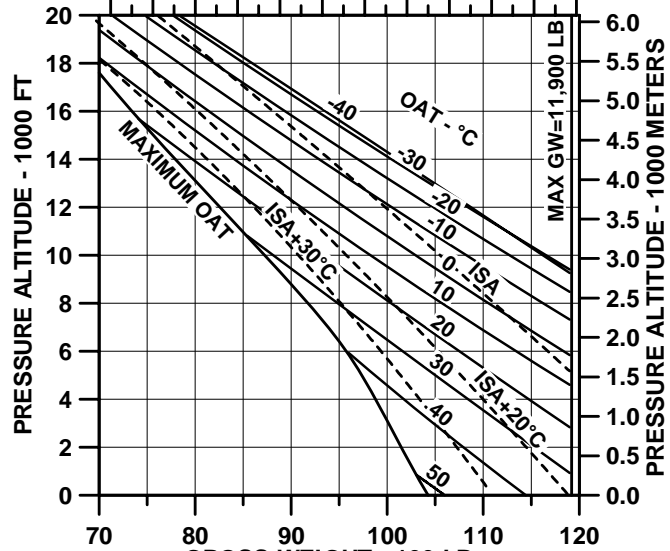

OGE HOVER WAT LIMITATION

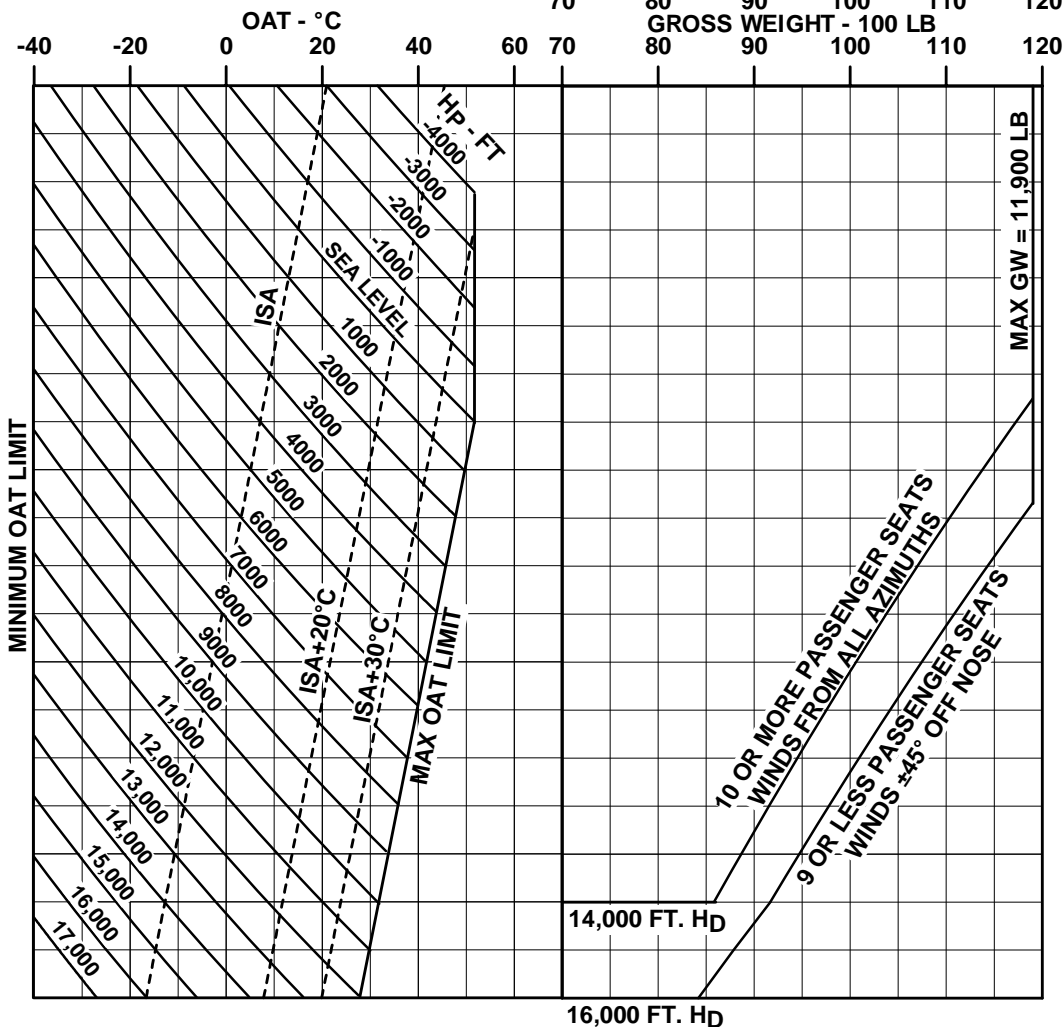

THE DATA SET FORTH ON THIS DOCUMENT ARE GENERAL IN NATURE AND MAY VARY WITH CONDITIONS. FOR PERFORMANCE DATA AND OPERATING LIMITATIONS FOR ANY SPECIFIC FLIGHT MISSION, REFERENCE MUST BE MADE TO THE APPROVED FLIGHT MANUAL.



SERVICE CEILING TWIN ENGINE OPERATION AT MAXIMUM CONTINUOUS POWER

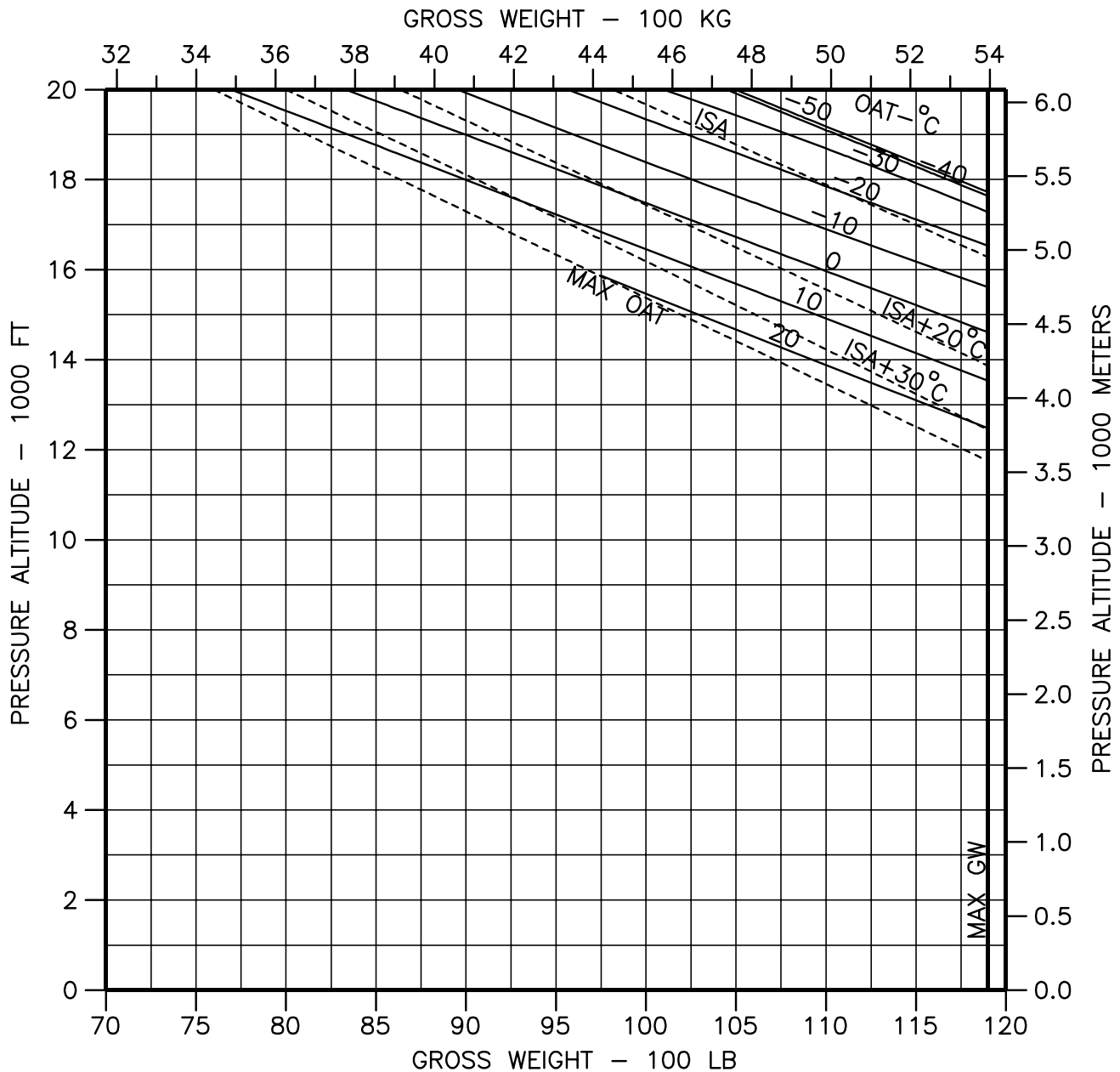

THE DATA SET FORTH ON THIS DOCUMENT ARE GENERAL IN NATURE AND MAY VARY WITH CONDITIONS. FOR PERFORMANCE DATA AND OPERATING LIMITATIONS FOR ANY SPECIFIC FLIGHT MISSION, REFERENCE MUST BE MADE TO THE APPROVED FLIGHT MANUAL.



**SERVICE CEILING
OEI @ CONTINUOUS POWER
STANDARD PT6T-3D ENGINE**

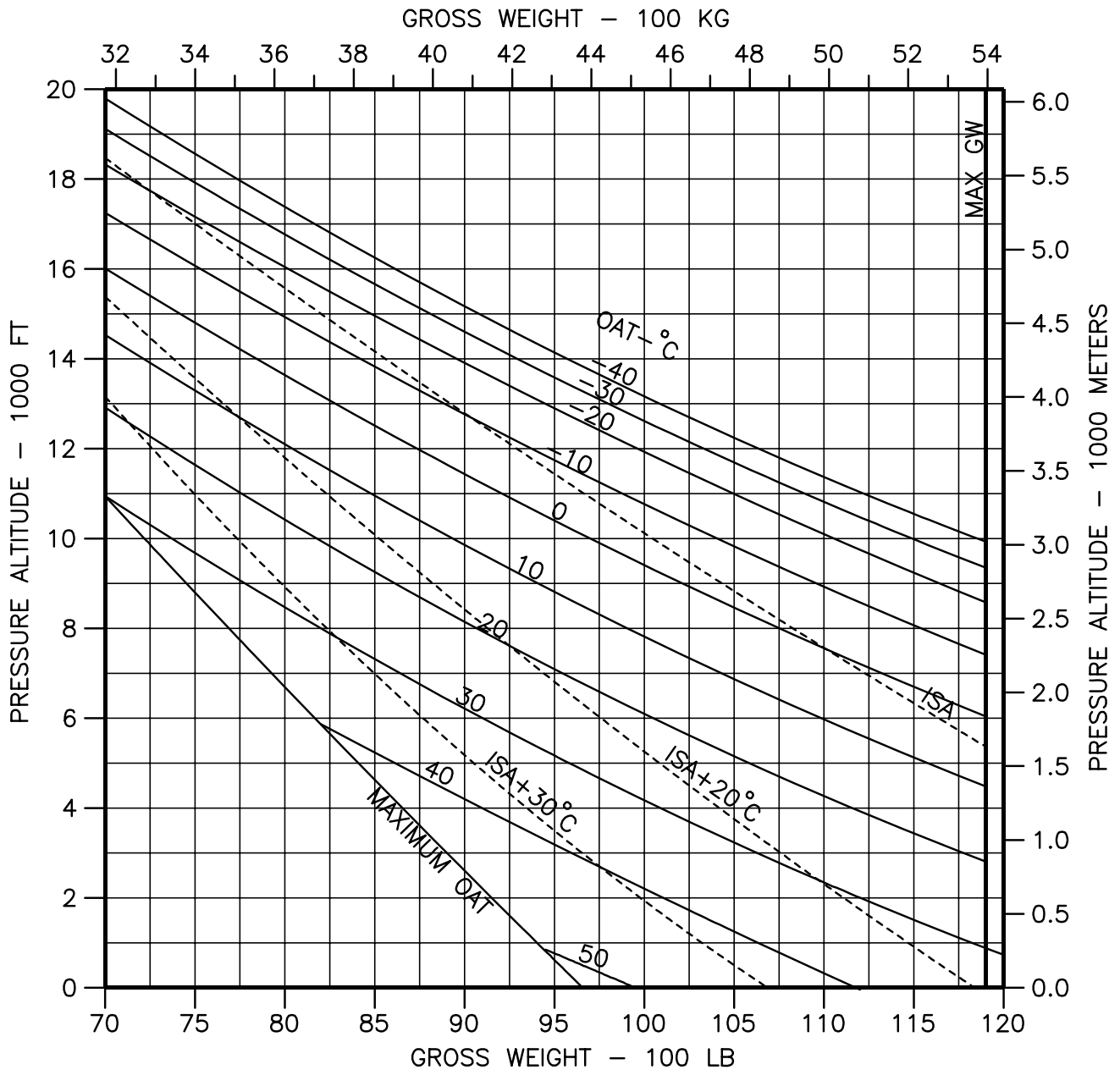

THE DATA SET FORTH ON THIS DOCUMENT ARE GENERAL IN NATURE AND MAY VARY WITH CONDITIONS. FOR PERFORMANCE DATA AND OPERATING LIMITATIONS FOR ANY SPECIFIC FLIGHT MISSION, REFERENCE MUST BE MADE TO THE APPROVED FLIGHT MANUAL.



INCREASED OEI PERFORMANCE OPTION
KIT No. 412-706-050
[PT6T-3DF ENGINE W/ OEI 30 MINUTE POWER]

Installation of Kit No. 412-706-050 provides the use of an additional 96 shaft horsepower [Uninstalled Thermodynamic Capability] under one engine inoperative conditions, for a period of thirty minutes.

412EP POWER RATINGS:

STANDARD;

(Pratt & Whitney PT6T-3D Twin Pac) Uninstalled Thermodynamic Capability, Each Takeoff , SHP	1800
Max Continuous Power, SHP	1800
OEI SHP (2-1/2minutes)	1140
OEI SHP (Continuous)	970

OPTIONAL;

(Pratt & Whitney PT6T-3DF Twin Pac) Uninstalled Thermodynamic Capability, Each Takeoff , SHP	1800
Max Continuous Power, SHP	1800
OEI SHP (2-1/2minutes)	1140
OEI SHP (30 minute power)	1066
OEI SHP (Continuous)	826

The kit consists of new Gas Producer gauges, ITT gauges, Engine/Transmission Torque gauge, and placards for the instrument panel. There is no increase in empty weight of the aircraft. Performance increase data is presented on the next page.

THE DATA SET FORTH ON THIS DOCUMENT ARE GENERAL IN NATURE AND MAY VARY WITH CONDITIONS. FOR PERFORMANCE DATA AND OPERATING LIMITATIONS FOR ANY SPECIFIC FLIGHT MISSION, REFERENCE MUST BE MADE TO THE APPROVED FLIGHT MANUAL.



SERVICE CEILING
OEI @ 30 MINUTE POWER
*** OPTIONAL PT6T-3DF ENGINE KIT ***
[ROTORCRAFT FLIGHT MANUAL SUPPLEMENT-56.3 or 56.4]

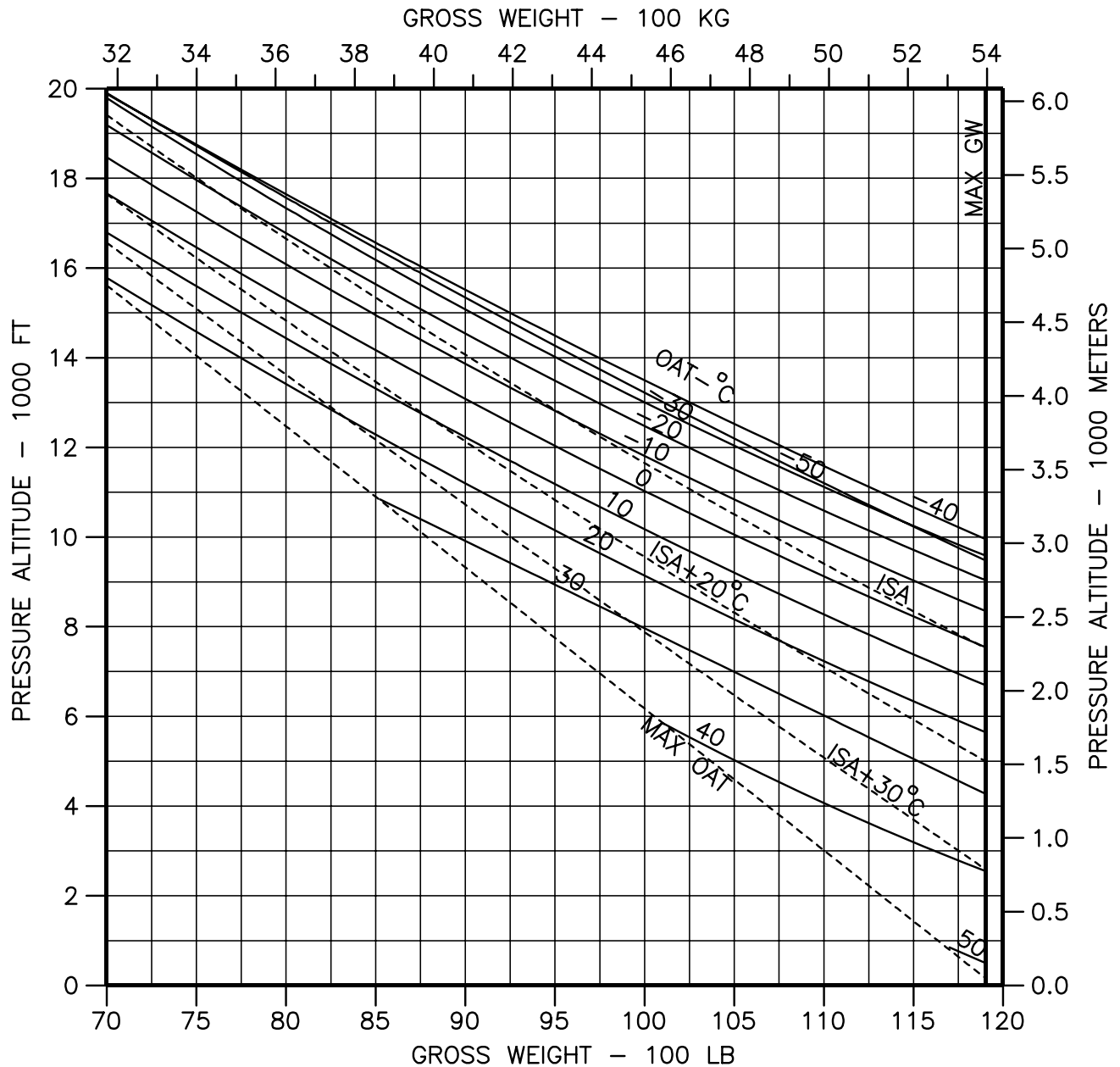

THE DATA SET FORTH ON THIS DOCUMENT ARE GENERAL IN NATURE AND MAY VARY WITH CONDITIONS. FOR PERFORMANCE DATA AND OPERATING LIMITATIONS FOR ANY SPECIFIC FLIGHT MISSION, REFERENCE MUST BE MADE TO THE APPROVED FLIGHT MANUAL.

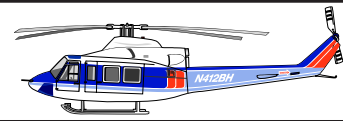

LEFT BLANK



CATEGORY A PERFORMANCE
GROUND LEVEL AND ELEVATED HELIPAD
DAY AND NIGHT
PT6T-3DF ENGINE OPTION

EQUIPMENT REQUIRED [INSTALLED AND FUNCTIONAL] TO PERFORM CATEGORY A OPERATIONS:

CATEGORY A VERTICAL TAKEOFF
DUAL CONTROLS
COPILOT INSTRUMENTS
PILOT & COPILOT ICS
RADAR ALTIMETER [VISIBLE TO BOTH PILOTS]

NOTE: ELEVATED HELIPAD CATEGORY A OPERATIONS REQUIRE PILOT AND COPILOT;
GROUND LEVEL HELIPAD CATEGORY A OPERATION MAY BE ACCOMPLISHED BY ONE PILOT

INFORMATION ON THE FOLLOWING PAGES PROVIDES A **BRIEF** EXPLANATION OF CATEGORY A OPERATION CAPABILITY FOR THE BELL 412EP (WHEN EQUIPPED WITH THE OPTIONAL PT6T-3DF ENGINE) OPTION KIT. THE WAT CHARTS INCLUDED MAY BE USED TO DETERMINE TAKEOFF OR LANDING WEIGHT CAPABILITY FOR GROUND LEVEL AND ELEVATED HELIPAD. FOR SIMPLIFICATION, ONLY ILLUSTRATIONS DESCRIBING TAKEOFF ARE SHOWN. ADDITIONAL INFORMATION FOR OTHER TYPES OF CATEGORY A OPERATION (REDUCED DROP DOWN HEIGHT, SHORT AND LONG RUNWAY) IS AVAILABLE IN THE FAA APPROVED ROTORCRAFT FLIGHT MANUAL SUPPLEMENT.

DEFINITIONS:

CATEGORY "A" TAKEOFF; OPERATION OF THE HELICOPTER IN SUCH A MANNER THAT IF ONE ENGINE FAILS AT ANY TIME AFTER THE START OF THE TAKEOFF THE HELICOPTER CAN:

1. PRIOR TO THE **TDP** (TAKEOFF DECISION POINT) RETURN TO AND SAFELY STOP ON THE TAKEOFF AREA; OR
2. AT OR AFTER THE **TDP** , CLIMB OUT FROM THE POINT OF FAILURE AND ATTAIN SINGLE ENGINE FORWARD FLIGHT.

CATEGORY "A" LANDING; OPERATION OF THE HELICOPTER IN SUCH A MANNER THAT IF ONE ENGINE FAILS AT ANY TIME DURING THE LANDING APPROACH THE HELICOPTER CAN:

1. AT OR PRIOR TO THE **LDP** (LANDING DECISION POINT) CLIMB OUT FROM THE POINT OF FAILURE AND ATTAIN SINGLE ENGINE FORWARD FLIGHT; OR
2. AFTER THE **LDP** , SAFELY STOP ON THE LANDING AREA.



GROUND LEVEL HELIPAD EXPLANATION

GROUND LEVEL HELIPAD TAKEOFF PROFILE DAY AND NIGHT

THE GROUND LEVEL TAKEOFF TECHNIQUE CONSISTS OF A VERTICAL / REARWARD TAKEOFF TO 120 FT TO THE TDP; THEN ACCELERATION TO V_{TOSS} (40KIAS), WITH SUBSEQUENT CLIMBOUT AT V_Y (70KIAS), TO 200FT.

GROUND LEVEL HELIPAD;

FOR A GROUND LEVEL HELIPAD THE ASSOCIATED TAKEOFF & LANDING LIMIT CHART ASSURES 15 FEET (4.6 METERS) GROUND LEVEL CLEARANCE AFTER TDP. THE MINIMUM **GROUND LEVEL HELIPAD SIZE IS 87 BY 75 FEET (25.9 BY 26.5 METERS)** WITH 25 FEET (7.6 METERS) CLEAR AREA AROUND HELIPAD IN TAKEOFF DIRECTION.

**NORMAL TAKEOFF (AEO)
ALL ENGINES OPERATING**

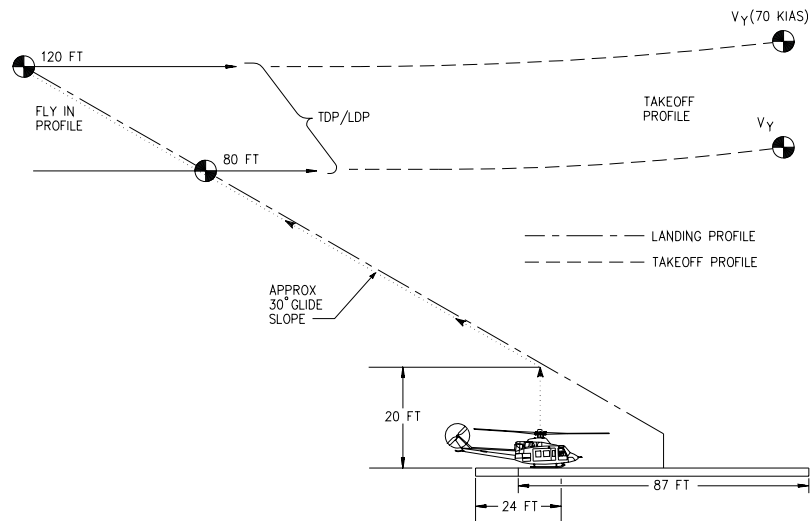

**EMERGENCY TAKEOFF OR LANDING (OEI)
ONE ENGINE INOPERATIVE**

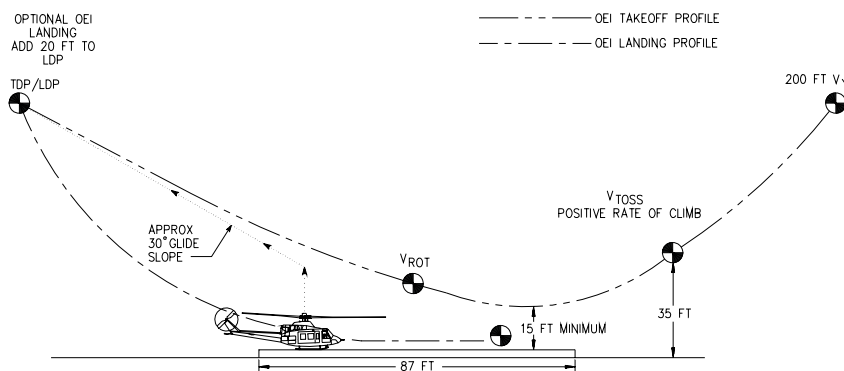

V_{ROT} = ROTATE SPEED {VELOCITY WHERE AIRSPEED INDICATOR HAS PERCEPTIBLE MOTION}.

THE DATA SET FORTH ON THIS DOCUMENT ARE GENERAL IN NATURE AND MAY VARY WITH CONDITIONS. FOR PERFORMANCE DATA AND OPERATING LIMITATIONS FOR ANY SPECIFIC FLIGHT MISSION, REFERENCE MUST BE MADE TO THE APPROVED FLIGHT MANUAL.



**CATEGORY A TAKEOFF AND LANDING LIMIT
GROUND LEVEL HELIPAD (DAY AND NIGHT)
PT6T-3DF ENGINE OPTION
2.5 MIN OEI POWER, 103% ROTOR RPM**

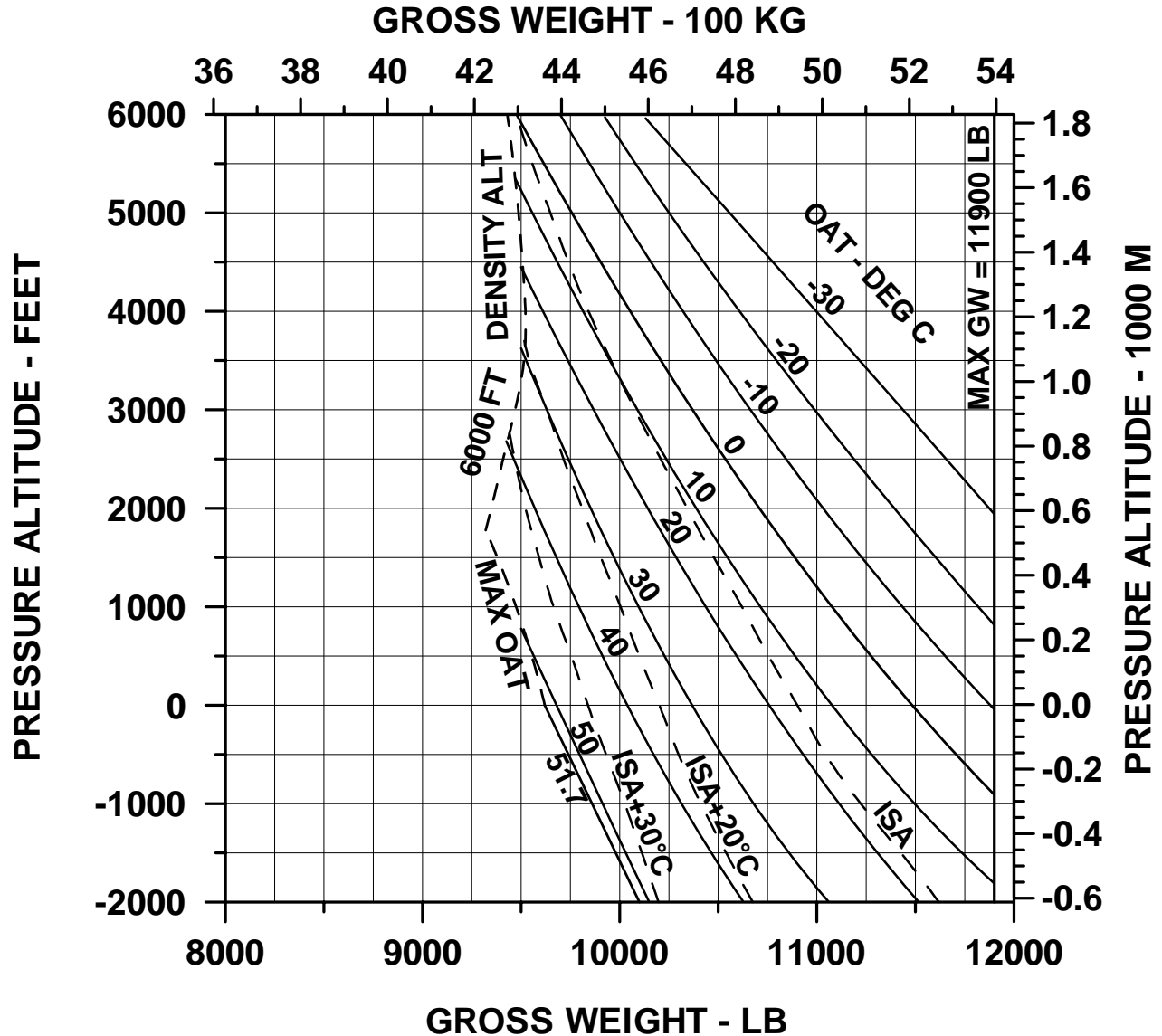

USING THE CHART;

1. ENTER THE CHART AT THE PRESSURE ALTITUDE OF THE TAKEOFF / LANDING HELIPAD
2. FOLLOW THE GRAPH LINE HORIZONTALLY TO THE APPROPRIATE OAT (OUTSIDE AIR TEMPERATURE) TREND LINE.
3. FOLLOW THE GRAPH LINE VERTICALLY TO THE APPROPRIATE GROSS WEIGHT.
4. THE INDICATED GROSS WEIGHT IS TAKEOFF / LANDING CAPABILITY WITH ZERO HEADWIND.

NOTE: CATEGORY A TAKEOFF AND LANDING HAS NOT BEEN DEMONSTRATED AND IS NOT APPROVED ABOVE 6,000 FEET / 1829 METERS **DENSITY ALTITUDE**.

THE DATA SET FORTH ON THIS DOCUMENT ARE GENERAL IN NATURE AND MAY VARY WITH CONDITIONS. FOR PERFORMANCE DATA AND OPERATING LIMITATIONS FOR ANY SPECIFIC FLIGHT MISSION, REFERENCE MUST BE MADE TO THE APPROVED FLIGHT MANUAL.



ELEVATED HELIPAD EXPLANATION

ELEVATED HELIPAD
TAKEOFF PROFILE
DAY OR NIGHT

THE TAKEOFF TECHNIQUE CONSISTS OF A VERTICAL TAKEOFF TO 35 FT, AND LATERAL MOVEMENT 35 FT FROM THE CENTER OF THE HELIPAD TO THE **TDP**; THEN ACCELERATION TO V_{TOSS} (40KIAS), WITH SUBSEQUENT CLIMBOUT AT V_y (70KIAS), TO 200FT.

ELEVATED HELIPAD;

FOR A HELIPAD 90 FEET (27.4 METERS) HIGH OR GREATER, THE ASSOCIATED TAKEOFF & LANDING LIMIT CHART ASSURES 15 FEET (4.6 METERS) VERTICAL OBSTACLE CLEARANCE AFTER **TDP**. ADDITIONAL CHARTS ARE AVAILABLE IN THE ROTORCRAFT FLIGHT MANUAL SUPPLEMENT FOR REDUCED DROP DOWN HEIGHT. THE MINIMUM **ELEVATED HELIPAD DIAMETER IS 65 FEET (19.8 METERS)**.

**NORMAL TAKEOFF (AEO)
ALL ENGINES OPERATING**

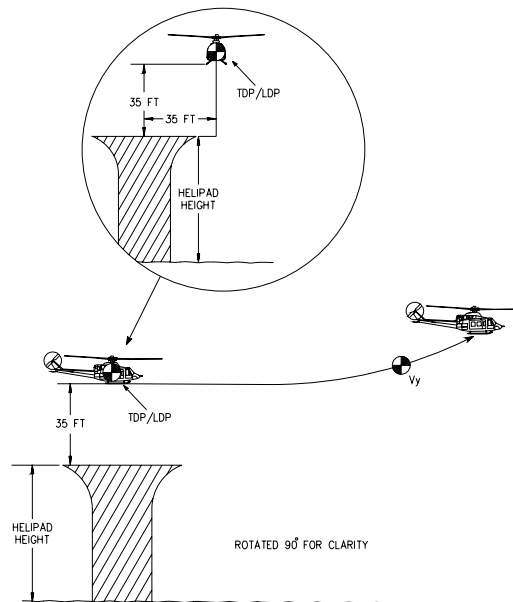

**EMERGENCY TAKEOFF
OR LANDING (OEI)
ONE ENGINE INOPERATIVE**

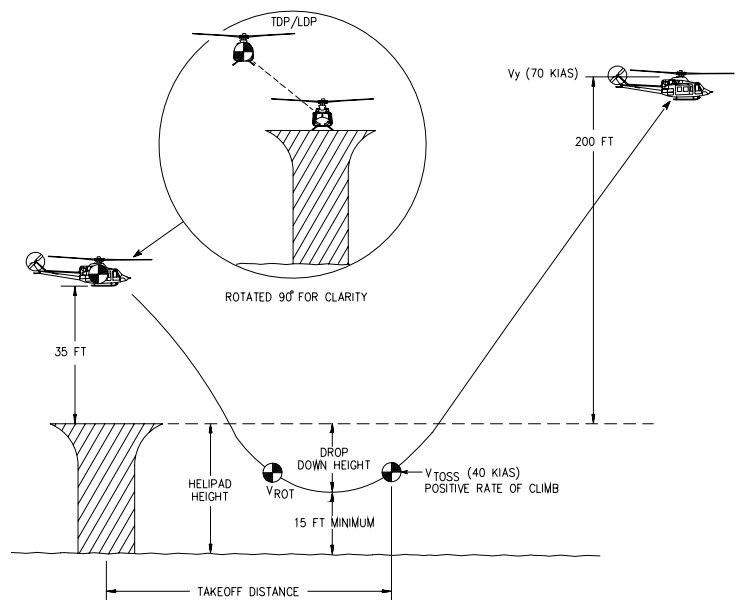

V_{ROT} = ROTATE SPEED{VELOCITY WHERE AIRSPEED INDICATOR HAS PERCEPTIBLE MOTION}.

THE DATA SET FORTH ON THIS DOCUMENT ARE GENERAL IN NATURE AND MAY VARY WITH CONDITIONS. FOR PERFORMANCE DATA AND OPERATING LIMITATIONS FOR ANY SPECIFIC FLIGHT MISSION, REFERENCE MUST BE MADE TO THE APPROVED FLIGHT MANUAL.



**CATEGORY A TAKEOFF AND LANDING LIMIT
ELEVATED HELIPAD (DAY AND NIGHT)
PT6T-3DF ENGINE OPTION
2.5 MIN OEI POWER, 103% ROTOR RPM**

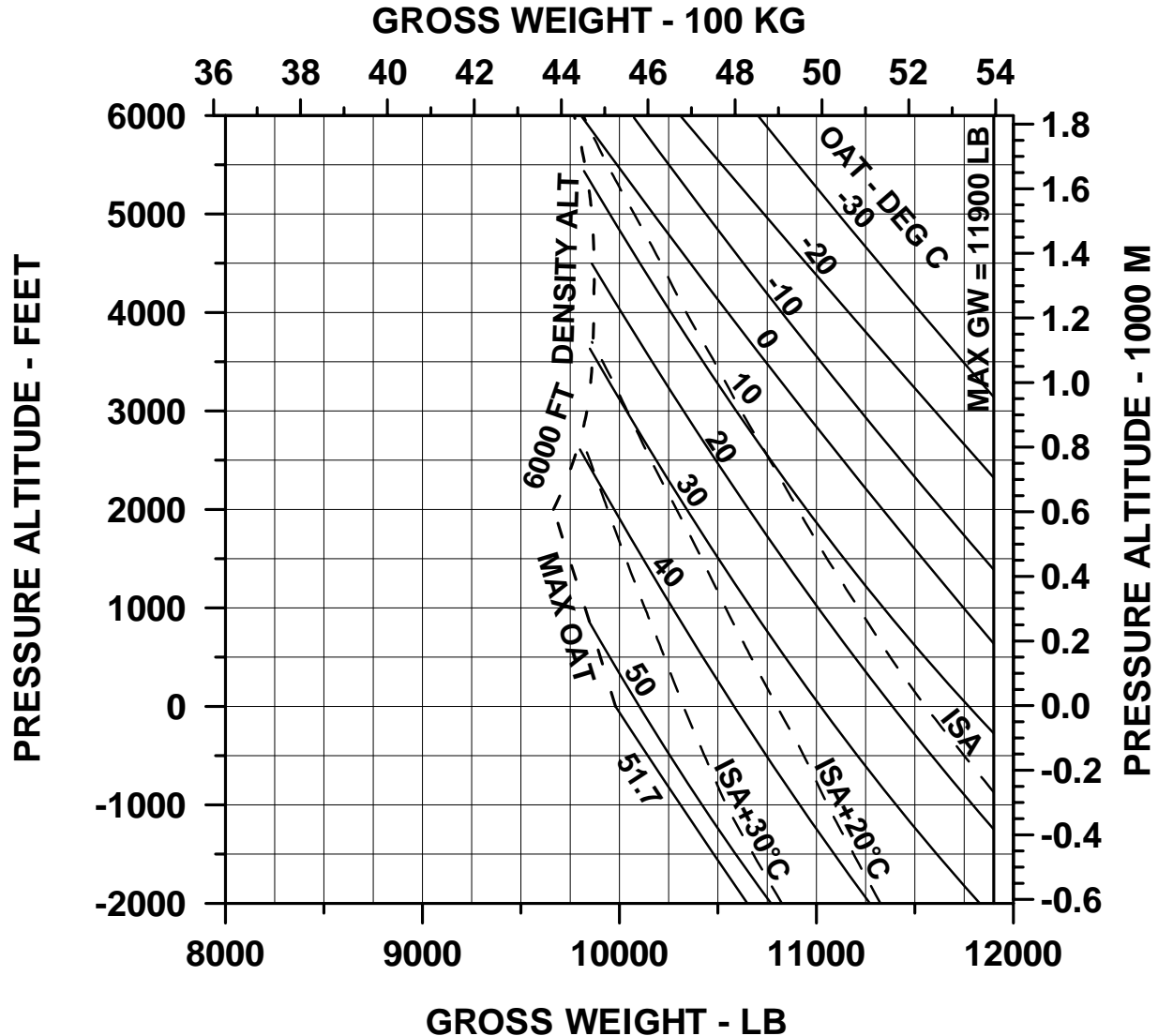

USING THE CHART;

1. ENTER THE CHART AT THE **PRESSURE ALTITUDE** OF THE TAKEOFF / LANDING HELIPAD
2. FOLLOW THE GRAPH LINE **HORIZONTALLY** TO THE APPROPRIATE **OAT** (OUTSIDE AIR TEMPERATURE) TREND LINE.
3. FOLLOW THE GRAPH LINE **VERTICALLY** TO THE APPROPRIATE **GROSS WEIGHT**.
4. THE INDICATED GROSS WEIGHT IS **TAKEOFF / LANDING CAPABILITY** **WITH ZERO HEADWIND**.

NOTE: CATEGORY A TAKEOFF AND LANDING HAS NOT BEEN DEMONSTRATED AND IS NOT APPROVED ABOVE 6,000 FEET / 1829 METERS **DENSITY ALTITUDE**.

THE DATA SET FORTH ON THIS DOCUMENT ARE GENERAL IN NATURE AND MAY VARY WITH CONDITIONS. FOR PERFORMANCE DATA AND OPERATING LIMITATIONS FOR ANY SPECIFIC FLIGHT MISSION, REFERENCE MUST BE MADE TO THE APPROVED FLIGHT MANUAL.

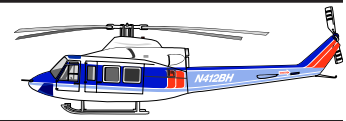

LEFT BLANK

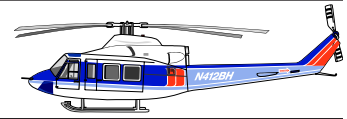

FUEL FLOW vs AIRSPEED
ISA & ISA+20° C
PRATT & WHITNEY CANADA
PT6T-3D ENGINE

NOTE: THE BEST ALLOWABLE CRUISE SPEED IS EITHER LONG RANGE CRUISE SPEED [LRC], OR WHEN SPEED IS LIMITED BY MAXIMUM CONTINUOUS CRUISE POWER [MCP] OR V_{NE} , THE MAXIMUM SPEED PERMITTED .



FUEL FLOW
TWIN ENGINE OPERATIONS (97% RPM) ZERO WIND
SEA LEVEL PRESSURE ALTITUDE OAT+15° C

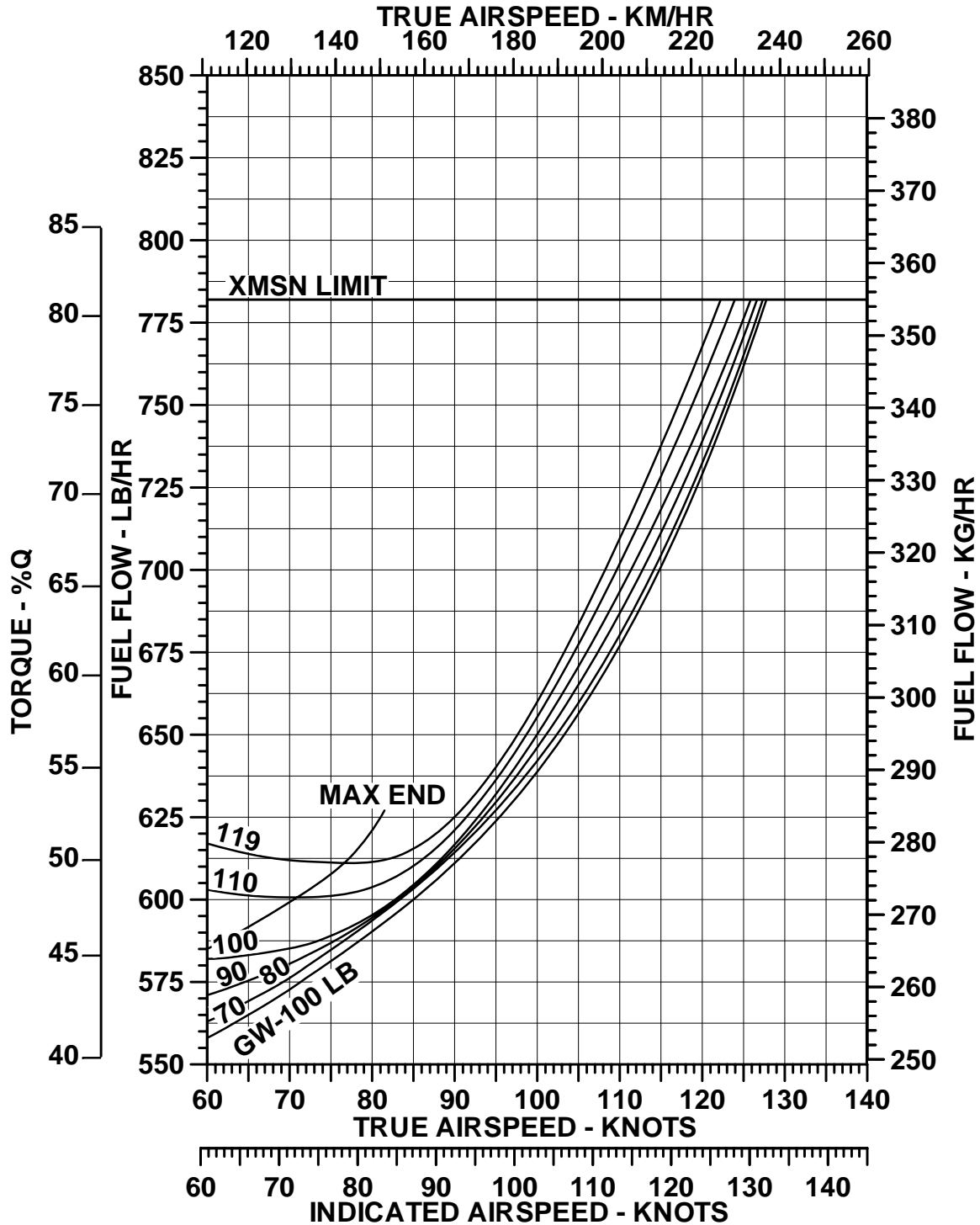

THE DATA SET FORTH ON THIS DOCUMENT ARE GENERAL IN NATURE AND MAY VARY WITH CONDITIONS. FOR PERFORMANCE DATA AND OPERATING LIMITATIONS FOR ANY SPECIFIC FLIGHT MISSION, REFERENCE MUST BE MADE TO THE APPROVED FLIGHT MANUAL.



FUEL FLOW
TWIN ENGINE OPERATIONS (97% RPM) ZERO WIND
2000 FEET PRESSURE ALTITUDE OAT+11° C

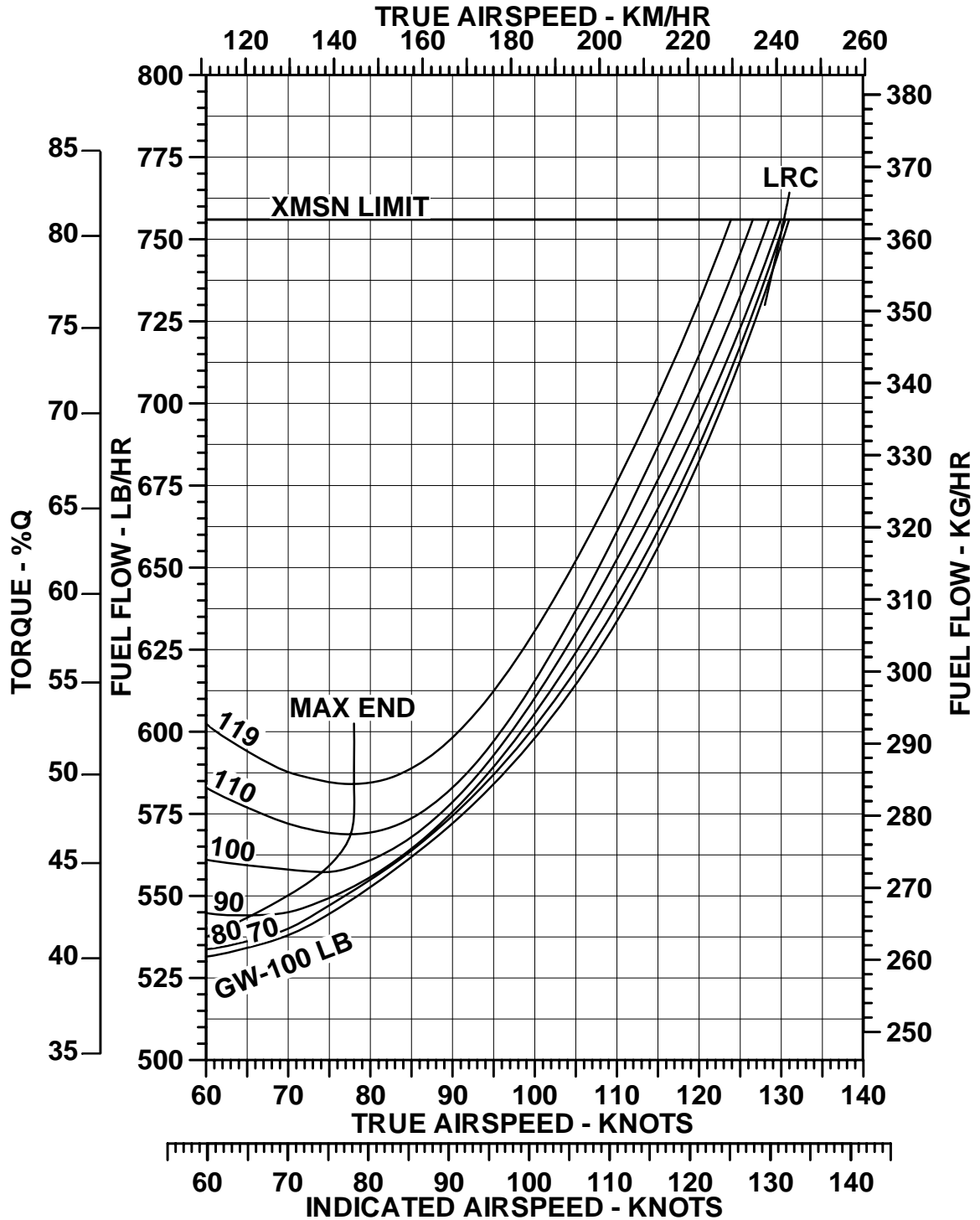

THE DATA SET FORTH ON THIS DOCUMENT ARE GENERAL IN NATURE AND MAY VARY WITH CONDITIONS. FOR PERFORMANCE DATA AND OPERATING LIMITATIONS FOR ANY SPECIFIC FLIGHT MISSION, REFERENCE MUST BE MADE TO THE APPROVED FLIGHT MANUAL.



FUEL FLOW
TWIN ENGINE OPERATIONS (97% RPM) ZERO WIND
4000 FEET PRESSURE ALTITUDE OAT+7° C

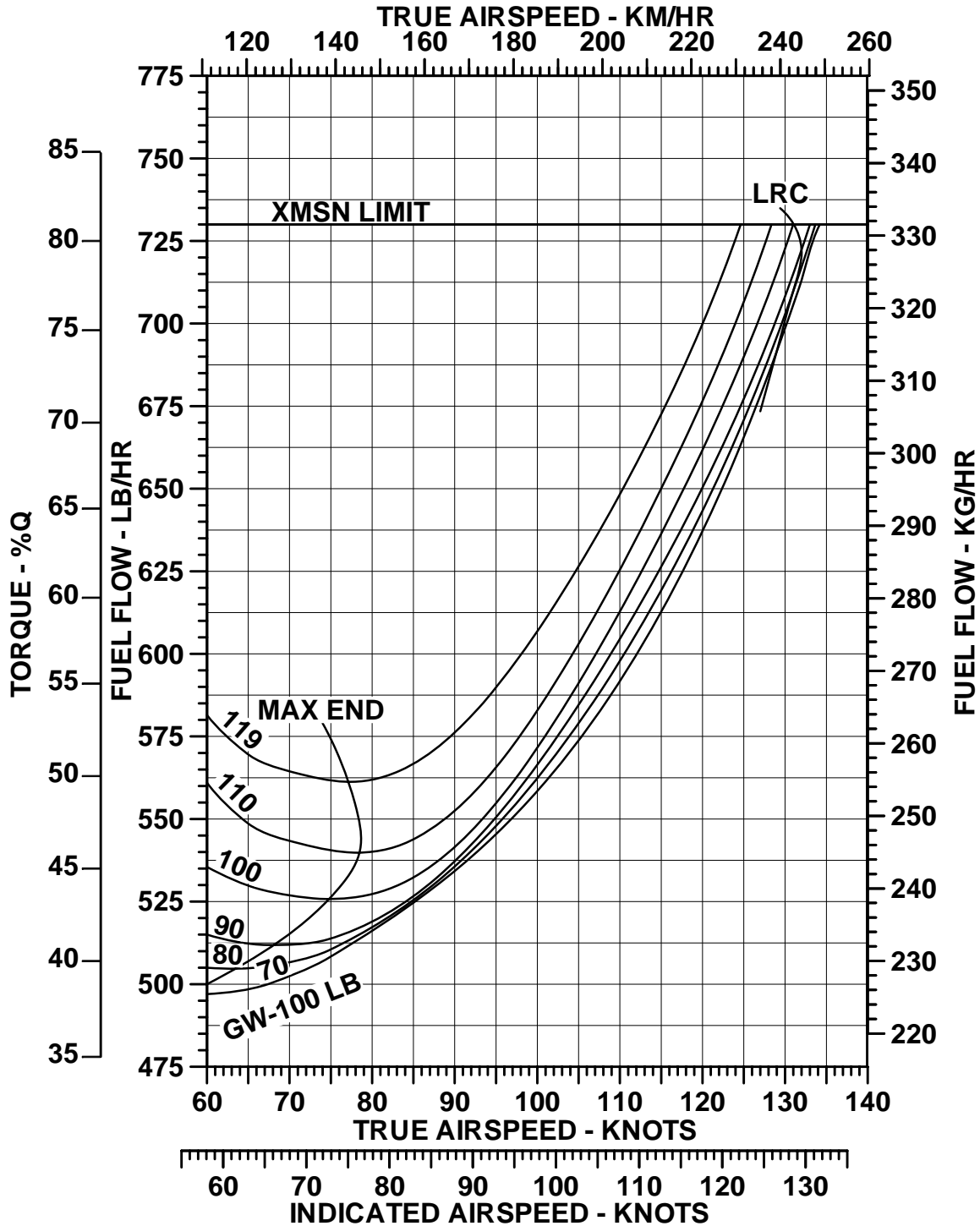

THE DATA SET FORTH ON THIS DOCUMENT ARE GENERAL IN NATURE AND MAY VARY WITH CONDITIONS. FOR PERFORMANCE DATA AND OPERATING LIMITATIONS FOR ANY SPECIFIC FLIGHT MISSION, REFERENCE MUST BE MADE TO THE APPROVED FLIGHT MANUAL.



FUEL FLOW
TWIN ENGINE OPERATIONS (97% RPM) ZERO WIND
6000 FEET PRESSURE ALTITUDE OAT+3° C

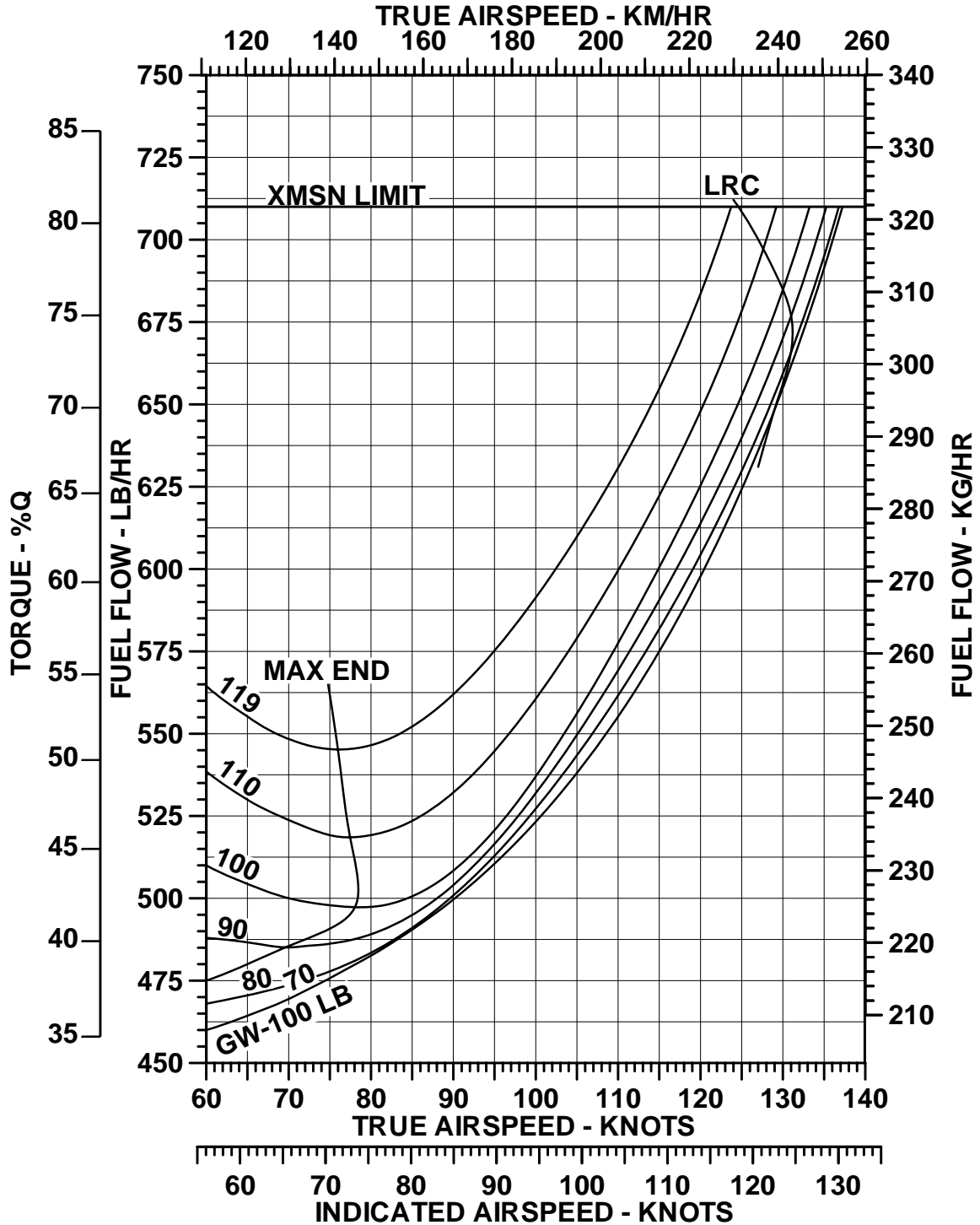

THE DATA SET FORTH ON THIS DOCUMENT ARE GENERAL IN NATURE AND MAY VARY WITH CONDITIONS. FOR PERFORMANCE DATA AND OPERATING LIMITATIONS FOR ANY SPECIFIC FLIGHT MISSION, REFERENCE MUST BE MADE TO THE APPROVED FLIGHT MANUAL.



FUEL FLOW
TWIN ENGINE OPERATIONS (97% RPM) ZERO WIND
8000 FEET PRESSURE ALTITUDE OAT-1° C

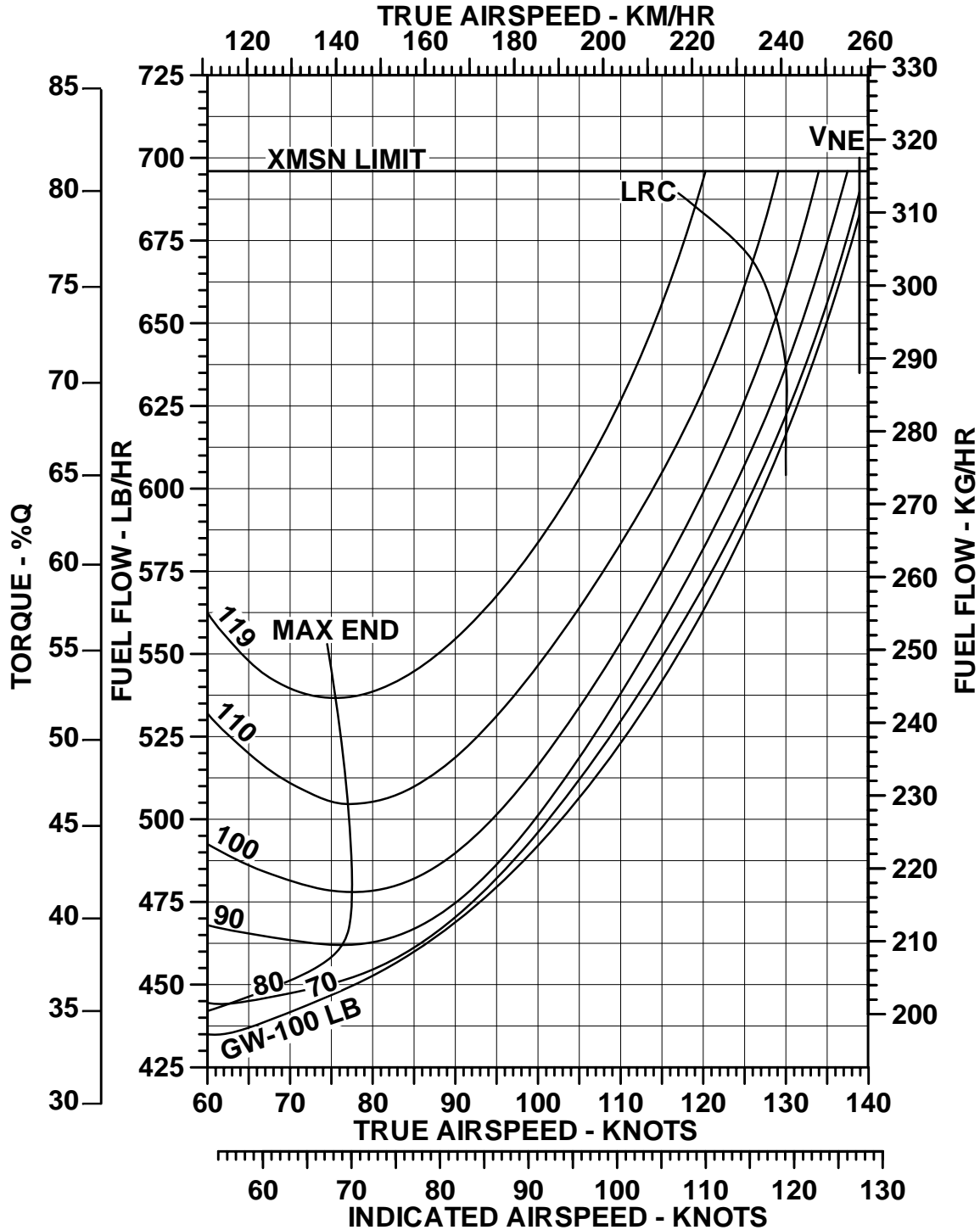

THE DATA SET FORTH ON THIS DOCUMENT ARE GENERAL IN NATURE AND MAY VARY WITH CONDITIONS. FOR PERFORMANCE DATA AND OPERATING LIMITATIONS FOR ANY SPECIFIC FLIGHT MISSION, REFERENCE MUST BE MADE TO THE APPROVED FLIGHT MANUAL.



FUEL FLOW
TWIN ENGINE OPERATIONS (97% RPM) ZERO WIND
SEA LEVEL PRESSURE ALTITUDE OAT+35° C

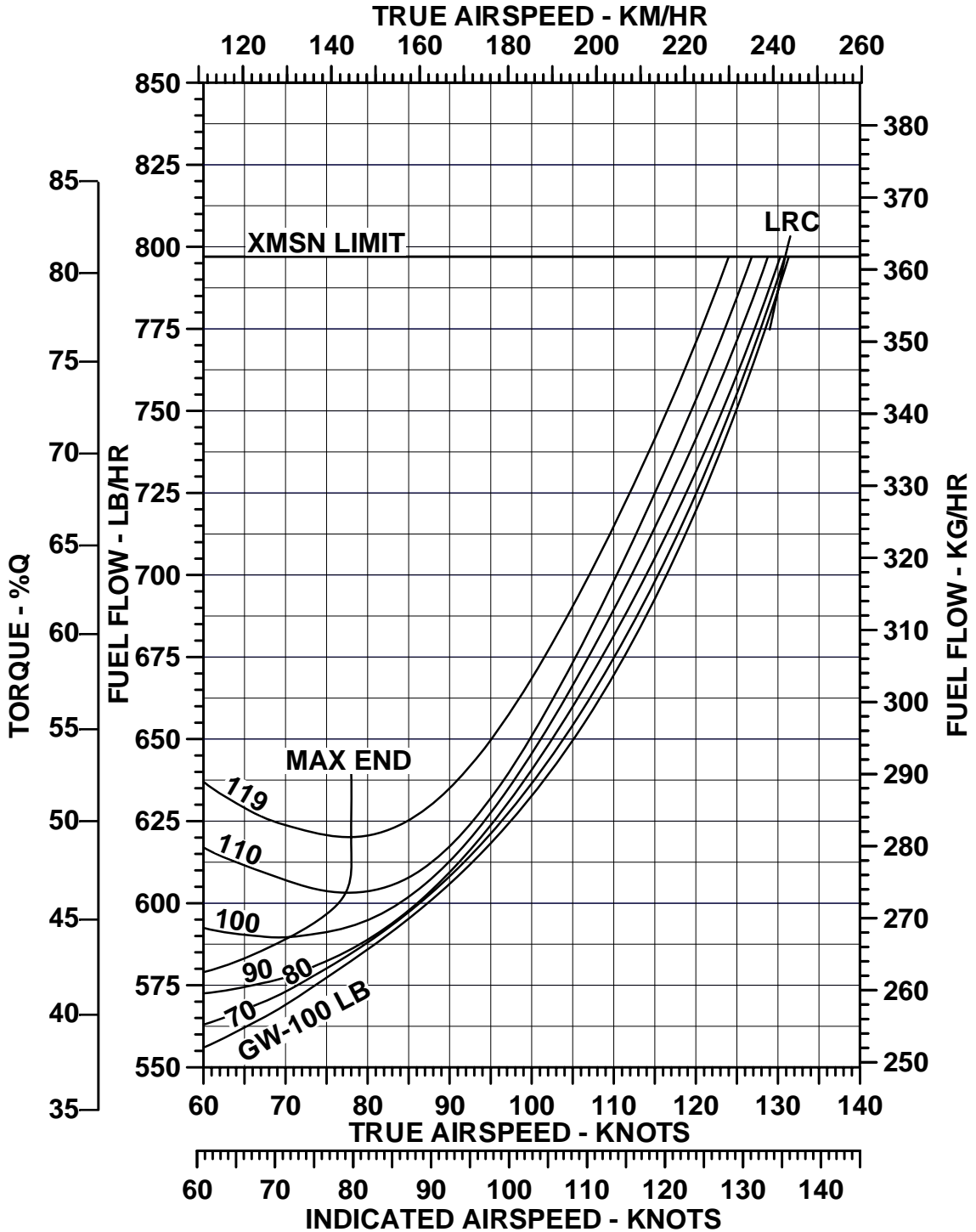

THE DATA SET FORTH ON THIS DOCUMENT ARE GENERAL IN NATURE AND MAY VARY WITH CONDITIONS. FOR PERFORMANCE DATA AND OPERATING LIMITATIONS FOR ANY SPECIFIC FLIGHT MISSION, REFERENCE MUST BE MADE TO THE APPROVED FLIGHT MANUAL.



FUEL FLOW
TWIN ENGINE OPERATIONS (97% RPM) ZERO WIND
2000 FEET PRESSURE ALTITUDE OAT+31° C

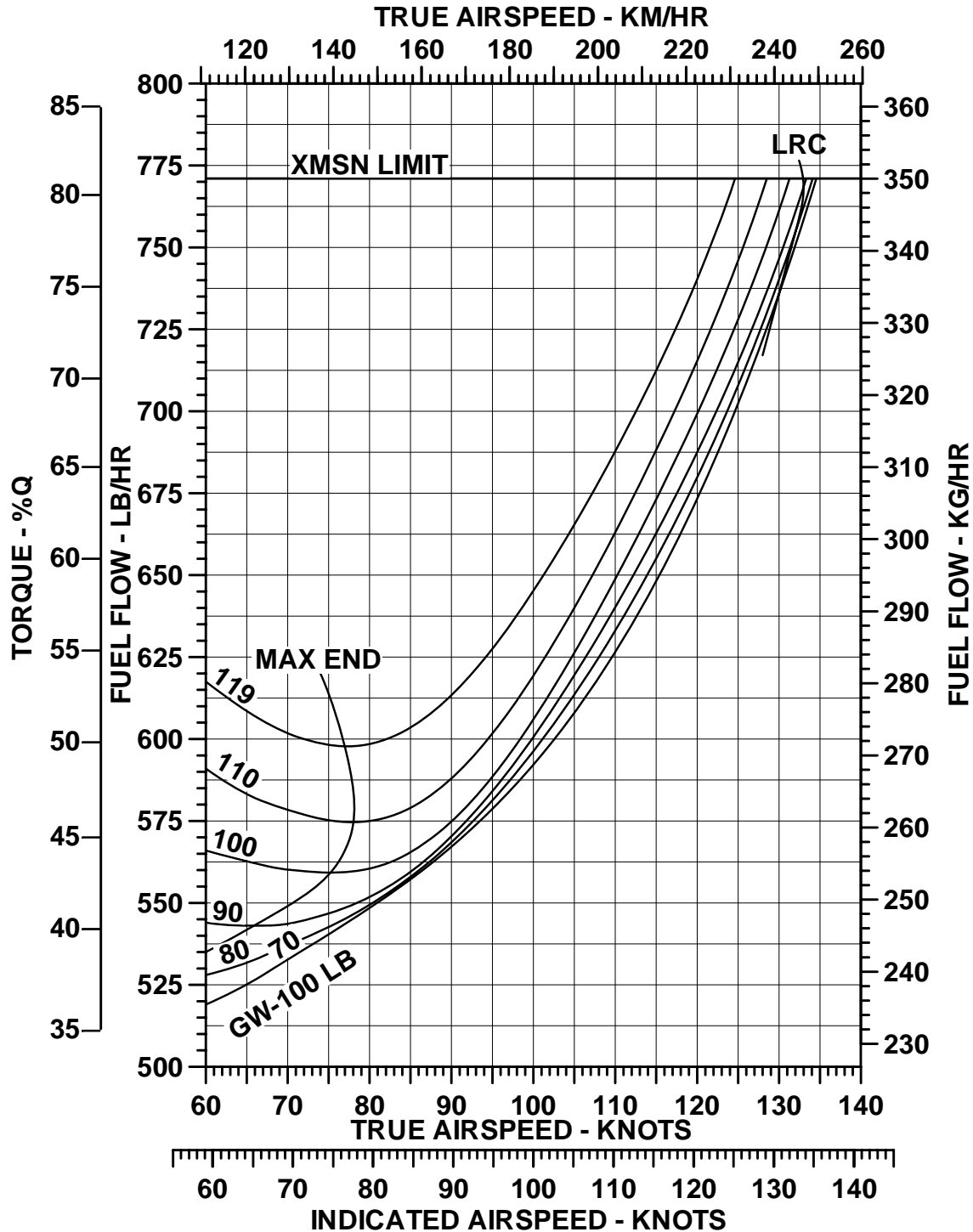

THE DATA SET FORTH ON THIS DOCUMENT ARE GENERAL IN NATURE AND MAY VARY WITH CONDITIONS. FOR PERFORMANCE DATA AND OPERATING LIMITATIONS FOR ANY SPECIFIC FLIGHT MISSION, REFERENCE MUST BE MADE TO THE APPROVED FLIGHT MANUAL.

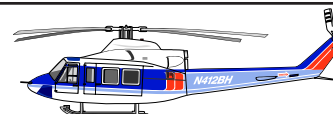

FUEL FLOW
TWIN ENGINE OPERATIONS (97% RPM) ZERO WIND
4000 FEET PRESSURE ALTITUDE OAT+27° C

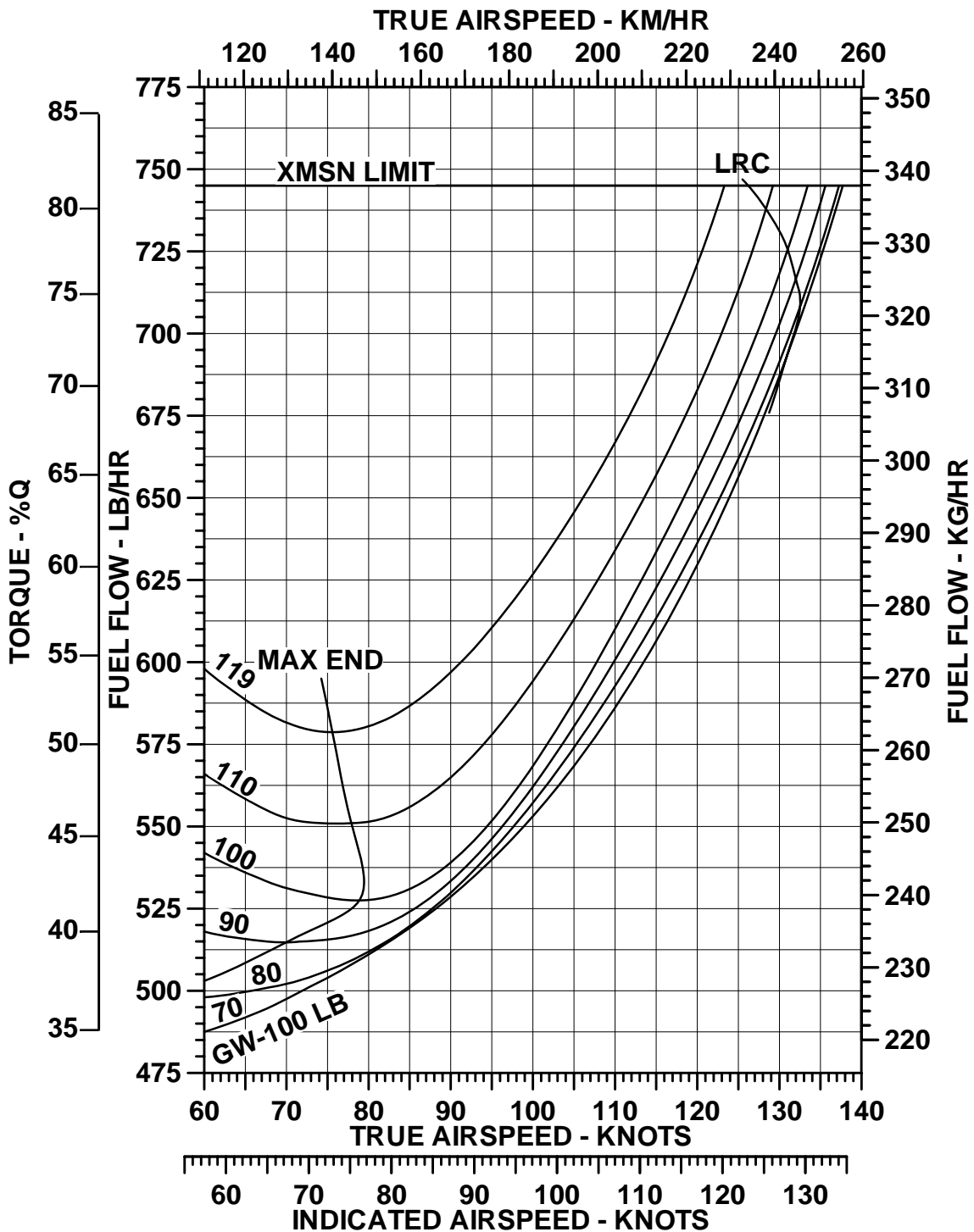

THE DATA SET FORTH ON THIS DOCUMENT ARE GENERAL IN NATURE AND MAY VARY WITH CONDITIONS. FOR PERFORMANCE DATA AND OPERATING LIMITATIONS FOR ANY SPECIFIC FLIGHT MISSION, REFERENCE MUST BE MADE TO THE APPROVED FLIGHT MANUAL.



FUEL FLOW
TWIN ENGINE OPERATIONS (97% RPM) ZERO WIND
6000 FEET PRESSURE ALTITUDE OAT+23° C

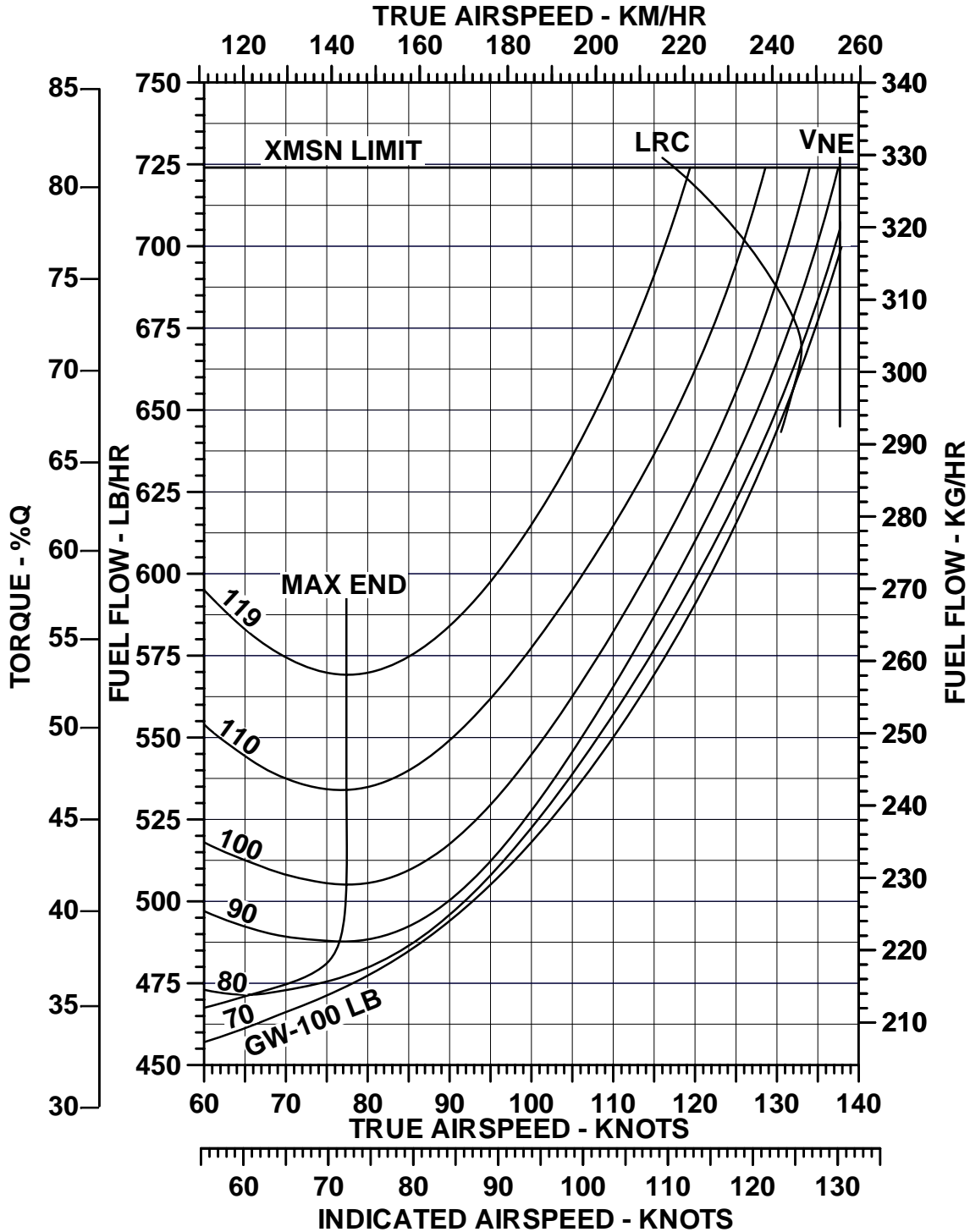

THE DATA SET FORTH ON THIS DOCUMENT ARE GENERAL IN NATURE AND MAY VARY WITH CONDITIONS. FOR PERFORMANCE DATA AND OPERATING LIMITATIONS FOR ANY SPECIFIC FLIGHT MISSION, REFERENCE MUST BE MADE TO THE APPROVED FLIGHT MANUAL.



FUEL FLOW
TWIN ENGINE OPERATIONS (97% RPM) ZERO WIND
8000 FEET PRESSURE ALTITUDE OAT+19° C

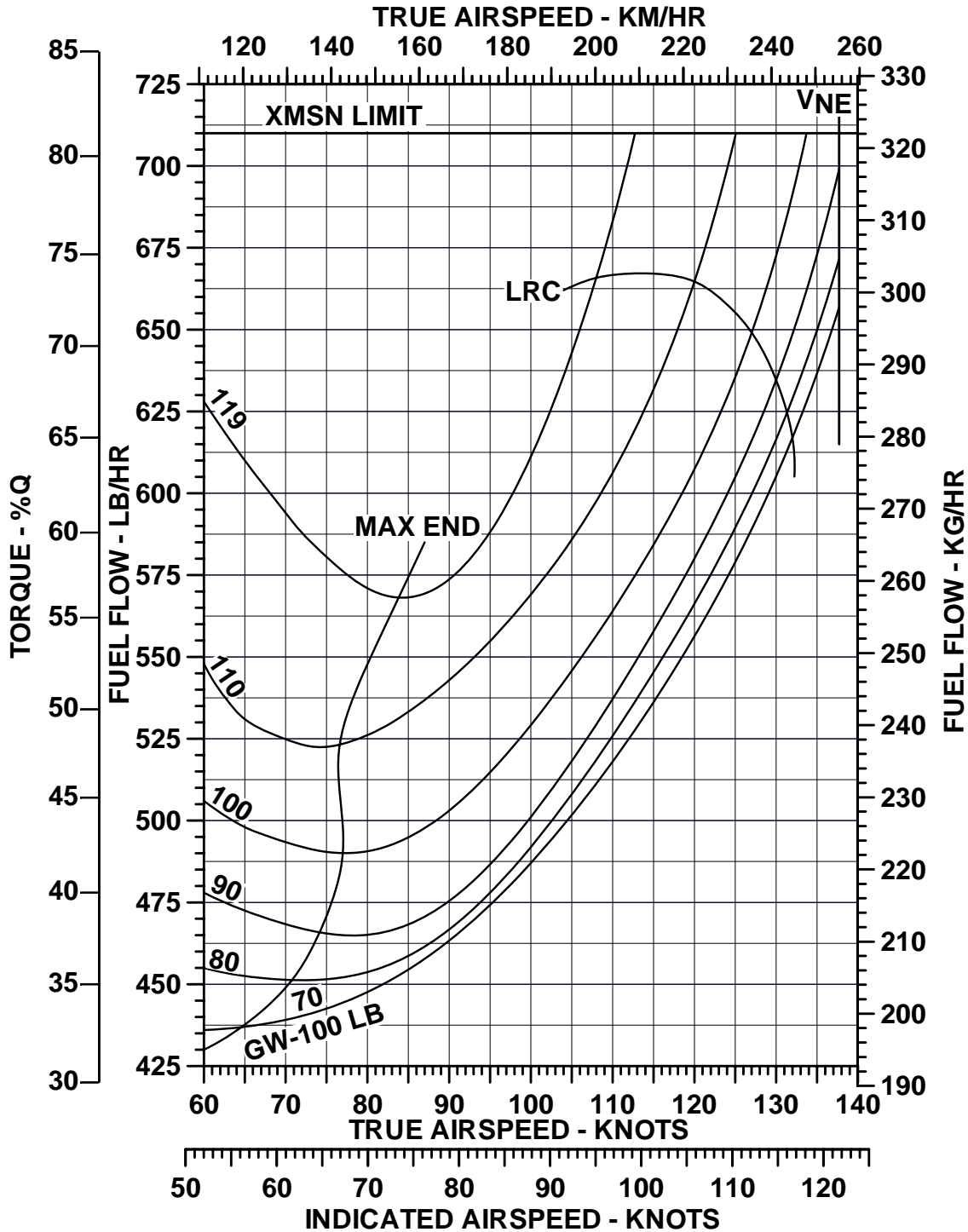

THE DATA SET FORTH ON THIS DOCUMENT ARE GENERAL IN NATURE AND MAY VARY WITH CONDITIONS. FOR PERFORMANCE DATA AND OPERATING LIMITATIONS FOR ANY SPECIFIC FLIGHT MISSION, REFERENCE MUST BE MADE TO THE APPROVED FLIGHT MANUAL.



COST OF OPERATIONS

INTRODUCTION

Bell Helicopter Textron's cost of operations data for current production helicopters is based on information from Bell operators and service facilities.

BHT's Product Support organization accumulates cost data from a diverse group of operators - large, small; sub-polar, subtropical; inland, coastal; corporate, charter. This information is analyzed to generate sample data for each production model which are averages of the field experience.

BHT intends to continue monitoring actual costs to enable annual updates of the data to maintain its currency.

The following discussion is provided to review the variables involved in the helicopter's direct and indirect cost of operations as well as its cost of ownership.

The total cost of helicopter ownership and operation involves both direct and indirect costs. The direct costs are those which are incurred essentially by the flight hour and include:

- Fuel, Lubricants
- Basic Airframe Maintenance
- Powerplant Maintenance

The indirect costs are not directly dependent upon the number of hours flown and include:

- Insurance
- Facilities (hangar, workshop, etc.)
- Crew Compensation
- Financial Factors (depreciation, investment tax credit, financing costs, etc.)

Sample direct operating cost data is available for each current production model. Detailed estimates for total costs relating to specific operations are available through the BHT regional marketing manager or corporate office using input data supplied by customer/prospect.

DIRECT COSTS

Fuel, Lubricants

A typical average value of fuel and lubricant costs is included in the sample data provided for each model.

Fuel consumption depends upon speed, temperature, externally-mounted accessories, sling loads, etc. A band of approximately 10% more or less than sample value will cover these factors for normal operations.

Fuel pricing varies considerably based on where the fuel is purchased geographically and whether it is purchased retail or in bulk. The sample cases use average retail purchase price prevalent at the time of the sample data are prepared.

Basic Airframe Maintenance

Airframe maintenance is divided into four categories:

- Periodic Inspections
- Overhauls
- Replacement of Retirement Parts
- Unscheduled

Periodic inspections include those inspection tasks, with their part requirements, listed in the Maintenance Manual for each model.

Man hours for periodic inspections can vary from the sample value provided because of differences in personal experience, tool and parts availability, facilities, environmental effects such as extremes in working temperatures. Man hour costs/hour are also variable among the Authorized Service Centers as a result of differences in local costs, overhead expenses and volume of work. The sample value is an average of costs per hour at Authorized Service Centers at the time of publication.

Overhauls include removal, disassembly, inspection, parts replacement, reassembly and reinstallation of certain components/assemblies at the periods stated in the BHT Maintenance Manual.

Overhaul man hour and parts requirements are subject to considerable variation depending upon the helicopter's operations and environments. The sample data reflect average values.

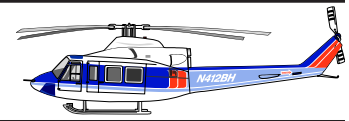

COST OF OPERATIONS (continued)

Retirement parts are those which are subject to disposal after an operating time stated in the Maintenance Manual. These are normally components of the rotors/control systems which are subject to oscillatory loads and are designed and tested for use over a finite number of flight hours rather than on their condition. The replacement at the required intervals requires some labor which is included in the man hour data in the sample.

Unscheduled maintenance encompasses labor and parts replacement for major maintenance not covered under the formal Maintenance Manual requirements for inspections and overhauls. It also includes those additional maintenance requirements imposed by the manufacturer through issue of Service Bulletins.

The sample data for periodic inspections provide for some minor unscheduled maintenance tasks resulting from the inspection.

Powerplant Maintenance

The powerplant (engine [s]) requires periodic inspection and overhauls. The overhaul periods are based on the number of operating hours or on the number of cycles, whichever is the first limit to be attained. Start cycles are a factor because thermal cycles are important in the design of the turbine engine's rotating components. Overhauls are performed by the engine manufacturer and/or at authorized facilities.

Powerplant overhaul can be performed for the engine as a unit, or in some cases for individual modules. (Modules can be gearbox, compressor, turbine, for example.) Each module can have its own overhaul period. Modular overhaul can be cost-effective for some operations and its use should be evaluated.

Engine or module exchanges can be made in lieu of overhaul. For details, contact the engine manufacturer or his authorized distributors/service centers. The sample costs are based on an average exchange.

The powerplant may also require unscheduled maintenance (unscheduled removals for repair, parts replacement).

INDIRECT COSTS

Insurance

Insurance rates are based on a number of factors including claim experience, type of operations, and crew qualifications. Rates can be obtained from insurance agent/broker.

Facilities

Facilities can include hangar, workshop, parts storage area, tools, ground support equipment and administrative area as appropriate to the specific operation.

Crew Compensation

The number of aircrew personnel depends on the individual operation; i. e., whether the normal crew consists of one or two pilots, hours per day flown, backup requirements for illness, vacation, etc.

Bell regional marketing managers can advise typical local costs for estimation purposes.

Financial Factors

Funding a helicopter purchase can be accomplished in a variety of ways, including cash, short term note, long term note, partnership, etc. For investment accounting, several depreciation methods also exist; straight line, double declining, sum of the years digits, etc. Value of resale is a significant factor.

Miscellaneous Factors

Staff expenses (other than aircrew and direct maintenance personnel), utilities, office expenses, etc.

OWNERSHIP ANALYSIS PROGRAM

Bell Helicopter Textron uses the **Life Cycle Cost 2006** computer program provided by **Conklin & de Decker Associates, Inc.** to determine ownership costs for an operators planned period of utilization for the aircraft. Conklin's Rotorcraft Analysis Office may be contacted at: Phone; (817)277-6403 or Fax; (817)277-6402.

Bell's regional marketing managers or corporate office personnel will be able to assist in preparing an ownership analysis which is customized for our customers specific individual conditions and needs.



SAMPLE - COST OF OPERATIONS
U S DOLLARS PER FLIGHT HOUR

Operator
Overhaul

Fuel and Lubricants

Fuel: (Note 1) [113Gal/Hr]	\$254.25
Lubricants: 3% of Fuel Cost	7.63

Airframe Direct Maintenance

Labor: (**Note 2**)

Inspection	(0.476 MH/FH)	30.94
Overhaul	(0.106 MH/FH)	6.87
Unscheduled and on-condition	(0.602 MH/FH)	39.14

Parts:

Inspections	9.47
Retirement	95.92
Overhaul	41.55
Unscheduled and on-condition	175.41

Powerplant Direct Maintenance

Overhaul (Including Accessories)	214.00
Line Maintenance (labor- Note 3)	(0.335MH/FH) 21.77

TOTAL AVERAGE COST / HR **\$896.95**

Note 1: Fuel at \$2.25 per gallon. Average fuel consumption for LRC at 1000 feet, ISA, (Jet-A at 6.8 Lb/Gal.)

Note 2: Labor rate assumed at \$65.00 per hour.

Note 3: Includes all scheduled and unscheduled maintenance and life limited parts replacement assuming normal operating environment.

COMPONENT OVERHAUL INTERVALS (Hours)

Swashplate & Support	2,500	Rotor Brake Quill	2,500	T/R Gearbox	5,000
Hub & Sleeve Assy	2,500	Transmission	5,000	T/R Driveshaft Hangar	5,000
T/R Hub Assembly	2,500	Intermediate Gearbox	5,000	Driveshaft Couplings	5,000
Mast Assembly	5,000	Starter Generator (2)	1,000	Flt Control Hyd Cyl (3)	2,500



LIFE LIMITED PARTS

<u>PART NUMBER</u>	<u>COMPONENT</u>	<u>LIFE IN FLIGHT HOURS</u>	<u>LIFE IN RIN</u>	<u>QTY PER A/C</u>	<u>LIST PRICE (EA)</u>	<u>TOTAL COST (FLT HR)</u>
<u>MAIN ROTOR COMPONENT</u>						
412-010-101-129	Yoke Assembly	5,000		2	56,211	\$22.48
412-010-190-105	Spindle	10,000		4	37,978	\$15.19
412-010-149-111	Pitch Horn	10,000		4	5,505	\$2.20
412-010-124-109	Retention Bolt	5,000		4	1,832	\$1.47
412-010-137-103	Retention Bolt	5,000		4	2,320	\$1.86
412-010-185-109	Damper Bridge	15,000		4	2,949	\$0.79
412-010-111-103	Fitting	5,000		4	4,220	\$3.38
412-010-170-105	Damper Bridge	10,000		4	2,452	\$0.98
<u>MAIN ROTOR CONTROLS</u>						
412-010-425-113	Pitch Link Tube	5,000		2	1,489	\$0.60
412-010-425-129	Pitch Link Tube	5,000		2	1,489	\$0.60
412-010-182-101	P/L Rod End Brg Upper	5,000		4	442	\$0.35
412-310-400-101	P/L Rod End Brg Lower	5,000		4	2,784	\$2.23
412-010-406-115	Swashplate Link Assy	5,000		2	9,256	\$3.70
412-010-445-105	Drive Hub Assy	10,000		1	8,415	\$0.84
412-010-403-113	Rephasing Lever Assy	5,000		2	8,168	\$3.27
412-010-403-117	Rephasing Lever Assy	5,000		2	8,168	\$3.27
412-010-405-111	Drive Link Assy	5,000		2	5,832	\$2.33
412-010-407-117	Swashplate Outer Ring	10,000		1	15,274	\$1.53
412-010-453-105	Swashplate Support Assy	5,000		1	12,702	\$2.54
204-010-404-001	Gimbal Ring Assy	9,000		1	2,919	\$0.32
204-011-408-107	Collective Sleeve	9,000		1	4,960	\$0.55
412-010-408-101	Collective Lever Assy	10,000		1	9,767	\$0.98
412-704-112-105	Control System Bolt	2,500		1	1,507	\$0.60
<u>PROPULSION & DRIVE SYSTEM</u>						
412-040-101-129A	Main Rotor Mast	10,000	60,000	1	29,617	\$2.96
412-010-160-105	Cap Assy	10,000		1	8,783	\$0.88
412-010-165-101	Cone	10,000		1	1,956	\$0.20
412-010-166-101	Drive Pin	10,000		8	403	\$0.32
412-010-186-103	Upper Cone Seat	10,000		1	3,205	\$0.32
412-010-177-117	Splined Plate Assy	10,000	60,000	1	7,805	\$0.78
412-018-056-105	Lower Cone Seat	10,000		1	19,969	\$2.00
412-010-179-105	Cone	10,000		1	4,213	\$0.42
<u>TAIL ROTOR CONTROLS</u>						
212-011-702-001	Tail Rotor Yoke	5,000		1	11,498	\$2.30
212-010-750-113	Tail Rotor Blade	5,000		2	11,740	\$4.70
<u>OTHER</u>						
412-704-116-101	Pendulum Damper Kit:					
412-010-264-101	Bracket Assy	10,000		4	6,916	\$2.77
412-010-264-105	Bracket Assy	10,000		4	8,032	\$3.21
412-010-263-101	Arm Assy	5,000		8	1,739	\$2.78
EWB0420D-7-36	Bracket Bolt	5,000		16	42	\$0.13
NAS6604H34	Weight Bolt	5,000		16	7	\$0.02
NAS6606H46	Weight Bolt	5,000		8	28	\$0.05
NAS6608D50	Arm Bolt	5,000		8	22	\$0.04
<u>TOTAL</u>						<u>\$95.92</u>

Prices and hours are subject to change without notice.

THESE DATA ARE PROVIDED FOR ILLUSTRATION PURPOSES. CONSULT MAINTENANCE DOCUMENTS AND BHT SPARE PARTS PRICING FOR CURRENT, OFFICIAL INFORMATION.



**Sample Illustrations of the
Standard Paint Schemes
are available from your
Bell Helicopter Sales Representative**

PAINT SELECTION NOTES:

- 1. COLOR RENDERINGS (ORIGINAL) MUST BE PROVIDED FOR ANY DEVIATION TO THE STANDARD SCHEMES (ALL MODELS).**
- 2. CUSTOM PAINT SCHEMES TO CUSTOMER SPECIFICATION ARE AVAILABLE, AND A PRICE QUOTE WILL BE PROVIDED ON REQUEST. PLEASE PROVIDE AS MUCH DETAIL AS POSSIBLE WHEN DESCRIBING SPECIAL INSTRUCTIONS AND CUSTOM PAINT SCHEMES.**
- 3. THE DANGER ARROW IS ALWAYS APPLIED ON THE TAIL BOOM BETWEEN THE HORIZONTAL STABILIZER AND THE TAIL ROTOR, NOT WITHSTANDING ANY OTHER ILLUSTRATIONS.**
- 4. UNLESS CLEARLY SPECIFIED (LOCATION, DIMENSION, COLOR), REGISTRATION MARKINGS WILL BE APPLIED PER FAA REGULATIONS (ALL MODELS).**
- 5. METALLIC PAINT CAN NOT BE APPLIED OVER RADOME AREAS WHEN A RADAR IS INSTALLED.**
- 6. PLACEMENT OF BELL MODEL LOGOS IS EFFECTED BY INDIVIDUAL PAINT SCHEMES, AND WILL BE APPLIED AT THE DISCRETION OF BELL HELICOPTER UNLESS OTHERWISE SPECIFIED BY THE CUSTOMER.**

For additional information visit the **Bell Helicopter Textron Website**

Homepage: www.bellhelicopter.com

BELL HELICOPTER TEXTRON INC.

Sales Contact Telephone Numbers

Sales Inquiries

U.S. Toll Free: 1-800-FLY-BELL

International/US: 817-280-2800

Email: marketing@bellhelicopter.textron.com

Regional Sales Areas

US/Canada 817-280-6789

Asia Pacific 817-280-2197

Europe/Middle East/Africa 817-280-3261

Latin America 817-280-2879

Used Helicopter Sales / www.BellNetX.com 817-280-2147

Fax: 817-280-8802

Customer Center

Ft. Worth / Alliance Airport Facility

P. O. Box 482

Ft. Worth, TX 76101-0482

817-280-6187 Fax: 817-280-8802

marketing@bellhelicopter.textron.com

Manufacturing Facility

Bell Helicopter Textron Canada Limited

12,800 rue de l'Avenir

Mirabel, Quebec

Canada J7J 1R4

450-437-3400 Fax: 450-437-2006

This book was produced by



Visual Communications Center

P. O. Box 482

Ft. Worth, TX 76101-0482



A Textron Company

P.O. Box 482, Fort Worth, Texas 76101,
Phone: (817) 280-2800, Fax: (817) 278-2800
www.bellhelicopter.textron.com

**BELL HELICOPTER TEXTRON
DIVISION OF TEXTRON CANADA LTD.**
12,800 rue de l' Avenir Mirabel, Quebec, Canada J7J1R4
Phone: (450) 437-2729 Fax: (450) 437-2066

The data set forth in this brochure are general in nature and may vary with conditions. For performance data and operating limitations for any specific flight mission reference must be made to the approved flight manual.

Written, Edited and Layout by:
Dave Wyatt
817-280-6918
E-Mail Address: dwyatt@bellhelicopter.textron.com

© 2005 Bell Helicopter Textron Inc.
All Rights Reserved.
Printed in USA
January 2005